



EcoQuip Vapor Abrasive

Blast System

334666B
EN

Vapor abrasive blast system. For professional use only. Not approved for use in explosive atmospheres or hazardous locations.



Important Safety Instructions

Read all warnings and instructions in this manual. Save these instructions.

125 psi (8.6 bar, 0.86 MPa) Maximum Working Pressure

See page 2 for Model information.

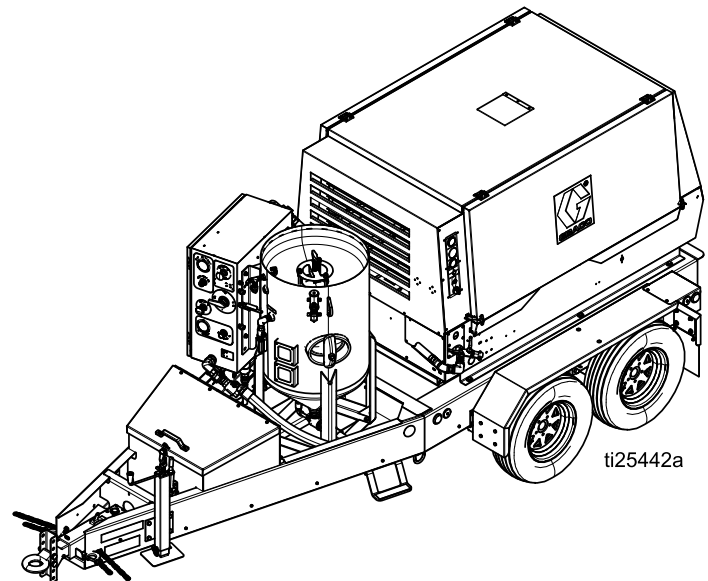

Contents

Models	2	Repairing the Diaphragm Valve.....	30
Related Manuals	2	Cleaning the Auto-Vent Valve	31
Warnings	3	Replacing the DataTrak Battery	32
Notes.....	5	Replacing the DataTrak Fuse	33
System Component Identification.....	6	Parts.....	34
EQ200T and EQ400T.....	6	EQ200T and EQ400T.....	34
DataTrak Controls.....	7	Enclosure	36
Pressure Relief Procedure	8	Trailers.....	38
Operation.....	9	Pressure Pot.....	41
Checklist Before Starting	9	Hose Schematic	42
Lifting the Trailer Systems	9	Vapor Abrasive Blast Systems and	
Connecting the Blast Hose and Air		Accessories	43
Hose.....	10	EcoQuip Skid Systems.....	43
Setting Up the Equipment.....	11	EcoQuip Trailer Systems.....	43
Blasting Tips.....	15	Mobile/Skid Units	44
Using the Wash Feature.....	17	Trailer Units.....	44
Refilling the Pot with Abrasive.....	18	Hoses	45
Shutting Down	19	Nozzles	45
Winterizing the Equipment.....	21	Common Spare Parts.....	46
Troubleshooting.....	22	Other Accessories.....	46
Troubleshooting Examples	26	Dimensions	47
Repair.....	28	Technical Specifications.....	48
Repairing the Main Air Regulator	28	Notes.....	49
Flushing the Diaphragm Valve	29	Graco Extended Warranty for EcoQuip™	
		Components	50

Models





Part	Description
EQ200T	EcoQuip 200 Vapor Blast System
EQ400T	EcoQuip 400 Vapor Blast System





Related Manuals

Manual Number	Product
313840	DataTrak
333397	Pump
334142	EQ100M
334143	EQ300M, EQ600M
334667	EQ300C, EQ600C

Warnings

The following warnings are for the setup, use, grounding, maintenance, and repair of this equipment. The exclamation point symbol alerts you to a general warning and the hazard symbols refer to procedure-specific risks. When these symbols appear in the body of this manual or on warning labels, refer back to these Warnings. Product-specific hazard symbols and warnings not covered in this section may appear throughout the body of this manual where applicable.

 WARNING	
 	<p>DUST AND DEBRIS HAZARD</p> <p>Use of this equipment can result in the release of potentially harmful dust or toxic substances from the abrasive being used, the coatings being removed, and the base object being blasted.</p> <ul style="list-style-type: none"> • For use only by sophisticated users familiar with applicable governmental safety and industrial hygiene regulators. • Use equipment only in a well-ventilated area. • Wear a properly fit-tested and government approved respirator suitable for the dust conditions. • Follow local ordinances and/or regulations for disposal of toxic substances and debris.
 	<p>EQUIPMENT MISUSE HAZARD</p> <p>Misuse can cause death or serious injury.</p> <ul style="list-style-type: none"> • Do not operate the unit when fatigued or under the influence of drugs or alcohol. • Do not exceed the maximum working pressure or temperature rating of the lowest rated system component. See Technical Data in all equipment manuals. • Do not use this equipment without hose restraints and coupler pins installed on all air and blast hose couplings. • Do not blast unstable objects. The high amount of fluid flow from the nozzle can potentially move heavy objects. • Do not exceed load rating of lift eyes. • Do not operate equipment on or stand on an unstable support. Keep effective footing and balance at all times. • Use fluids and solvents that are compatible with equipment wetted parts. See Technical Data in all equipment manuals. Read fluid and solvent manufacturer's warnings. For complete information about your material, request MSDS from distributor or retailer. • Do not leave the work area while equipment is energized or under pressure. • Turn off all equipment and follow the Pressure Relief Procedure when equipment is not in use. • Check equipment daily. Repair or replace worn or damaged parts immediately with genuine manufacturer's replacement parts only. • Do not alter or modify equipment. Alterations or modifications may void agency approvals and create safety hazards. • Make sure all equipment is rated and approved for the environment in which you are using it. • Use equipment only for its intended purpose. Call your distributor for information. • Route hoses and cables away from traffic areas, sharp edges, moving parts, and hot surfaces. • Do not kink or over bend hoses or use hoses to pull equipment. • Keep children and animals away from work area. • Comply with all applicable safety regulations.

 WARNING	
	<p>BURN HAZARD</p> <p>Equipment surfaces and fluid that is heated can become very hot during operation. To avoid severe burns:</p> <ul style="list-style-type: none"> • Do not touch hot fluid or equipment.
	<p>FIRE AND EXPLOSION HAZARD</p> <p>Flammable fumes, such as solvent, in work area can ignite or explode. To help prevent fire and explosion:</p> <ul style="list-style-type: none"> • Use equipment only in well ventilated area. • Abrasive material exiting blast nozzle can generate sparks. When flammable liquids are used near the blast nozzle or for flushing or cleaning, keep the blast nozzle at least 20 feet (6 meters) away from explosive vapors. • Keep work area free of debris, including solvent, rags and gasoline. • Keep a working fire extinguisher in the work area.
	<p>PERSONAL PROTECTIVE EQUIPMENT</p> <p>Wear appropriate protective equipment when in the work area to help prevent serious injury, including eye injury, hearing loss, inhalation of toxic fumes, and burns. Protective equipment includes but is not limited to:</p> <ul style="list-style-type: none"> • Protective eye wear • Protective shoes • Gloves • Hearing protection • Properly fit-tested and government approved respirator suitable for the dust conditions
	<p>RECOIL HAZARD</p> <p>Blast nozzle may recoil when triggered. If you are not standing securely, you could fall and be seriously injured.</p>

Notes

System Component Identification

EQ200T and EQ400T

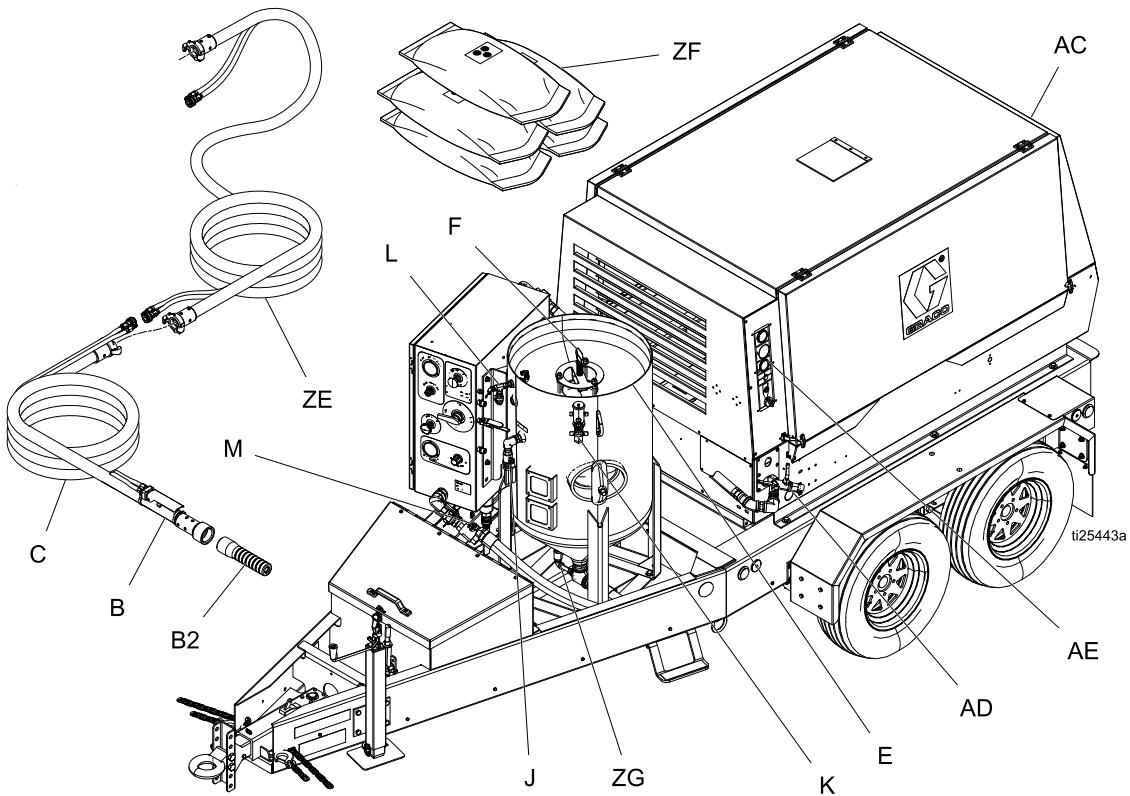
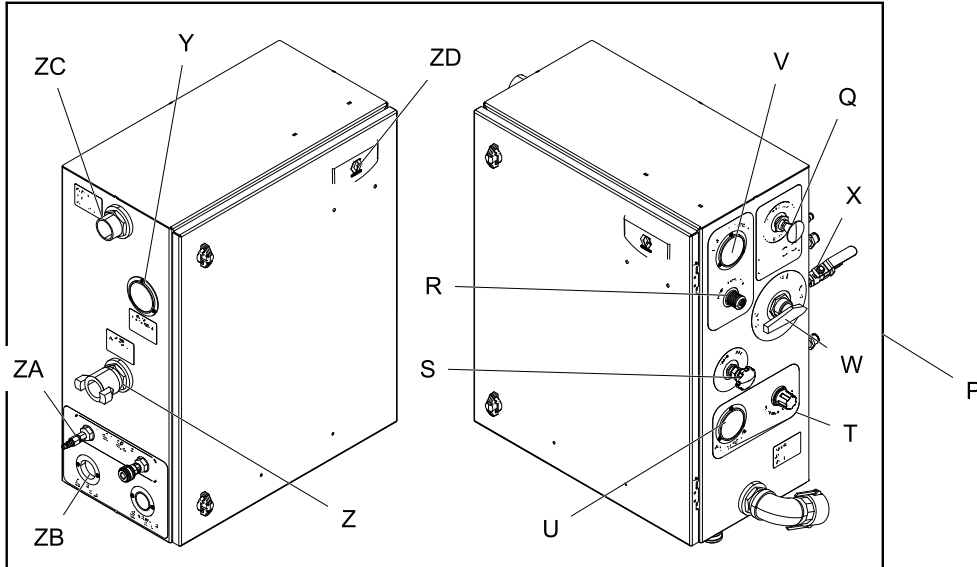

Key:

- B Blast Control Switch
- B2 Blast Nozzle
- C Blast Hose
- E Pot
- F Bung Pin
- J Pot Dump Valve
- K Auto Vent Valve
- L Blast Check Valve
- M Abrasive Ball Valve
- P Control Box
- Q Emergency Stop
- R Blast Air Regulator
- S Abrasive Meter
- T Pot Pressure Regulator
- U Pot Pressure Gauge

Key:

- V Blast Air Pressure Gauge
- W Selector Valve
- X Rinse Ball Valve
- Y Air Supply Connection
- Z Blast Connection
- ZA Pneumatic Control Connection
- ZB Electric Control Connection
- ZC Supply Air Pressure Gauge
- ZD DataTrak (see [DataTrak Controls, page 7](#))
- ZE Accessory Extension hose
- ZF Abrasive Material
- ZG Fill Port Check Valve
- AC Air Compressor
- AD Air Connections
- AE Air Compressor Controls

DataTrak Controls

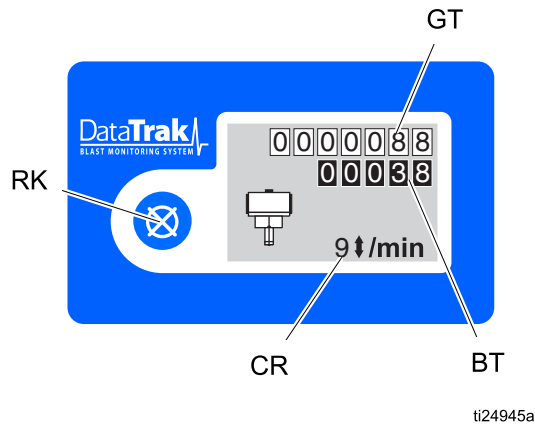

Key:

- RK Reset Key — Results in faults. Press and hold for three seconds to clear the batch totalizer.
- CR Cycle/Rate
- BT Batch Totalizer
- GT Grand Totalizer

Pressure Relief Procedure



Follow the Pressure Relief Procedure whenever you see this symbol.

<p>This equipment stays pressurized until pressure is manually relieved. To help prevent serious injury from pressurized fluid, such as splashing fluid, follow the Pressure Relief Procedure when instructed.</p>					

1. Turn the pot pressure regulator (PR) off.

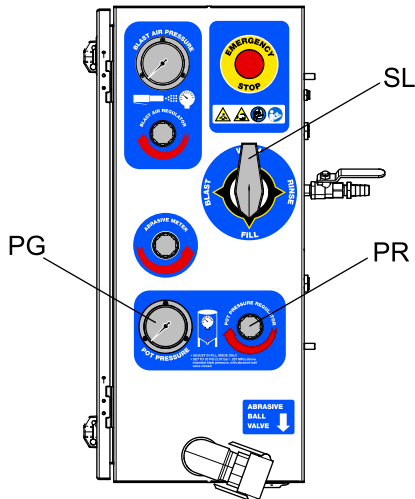

ti24111b

2. Close the abrasive ball valve.
3. Turn the compressor off and close the inlet ball valve. Close the compressor supply air valve. Engage the blast control switch to relieve pressure in the system. Then disconnect the air inlet hose from the system.
4. Turn the selector valve (SL) to FILL.
5. Open the dump valve.

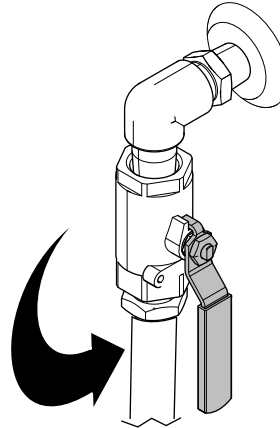

ti24112a

6. Verify that the pot pressure gauge (PG) displays zero pressure.

Operation

Checklist Before Starting

- Check the compressed air supply according to its operator manual. Make sure the air being supplied is clean and relatively free of moisture and oil to prevent water contamination of the air control components.
- Make sure air delivery valves are closed before the air supply compressor is started.
- Make sure all required hose restraints and coupler pins are in working condition and properly installed.
- Make sure the equipment is situated on level ground. Failure to keep the unit on level ground will make it difficult or impossible to purge all of the air from the pressure vessel.
- Make sure the equipment is properly supported on a surface that can hold its total weight. The weight of all personnel, the material being blasted, and any abrasive being stored must also be considered (see [Technical Specifications, page 48](#)).
- Make sure the water tank will remain fully supplied with clean water to avoid any possibility of the pump running dry during blasting.
- Make sure that the pot is clean and free of any internal debris.

- Make sure to use the correct type of blast control. Blasting with 150 feet (45 m) or more of blast hose requires the use of an electric blast control. An electric blast control can also be used on hose lengths below 150 feet (45 m).
- Make sure the blast hose is laid out as straight as possible between the equipment and the work site (a coiled blast hose will uncoil under pressure).

NOTICE

Sharp bends in the blast hose could cause the abrasive to wear through the hose and cause premature failure of the hose.

- Make sure the rubber gasket in each hose coupler is in working condition.

Lifting the Trailer Systems

- Lift the unit with a lift apparatus rated for 10,000 lb (4535 kg) minimum.
- Do not lift the system by the lift ring on top of the compressor.
- Do not lift the system by the tie-down rings on the trailer.

Connecting the Blast Hose and Air Hose

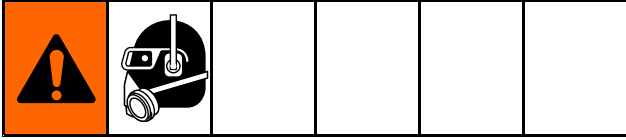

1. Make sure the inlet hose connections are tight, and that hose restraints are properly installed and secure.
2. Open the air supply valve (125 psi, 8.6 Bar, 0.86 MPa maximum). If necessary, use a regulator in the supply air line to meet these specifications.

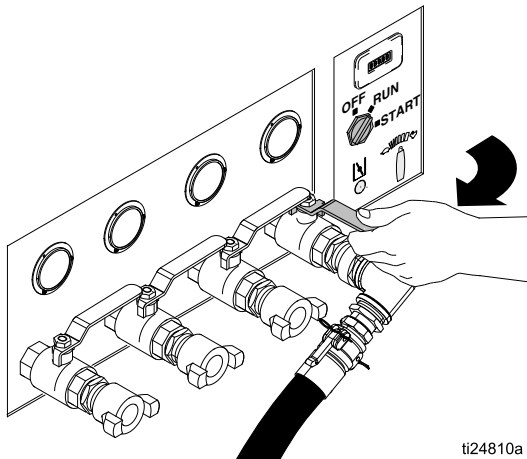

3. Connect the blast hose, hose restraints, control hoses, and coupler pins.

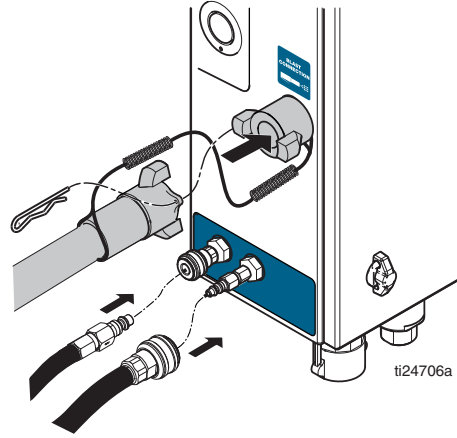

NOTE: If you are using an electric blast control, check all of the electrical connections from the panel to the blast control.

NOTICE

Make sure no electrical connections will be exposed to water. Exposure to water could cause a short circuit and damage the equipment.

Setting Up the Equipment

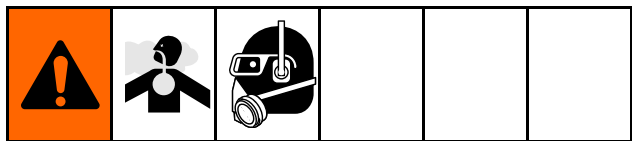

1. Disconnect the abrasive hose at the cam and groove with the abrasive ball valve closed.

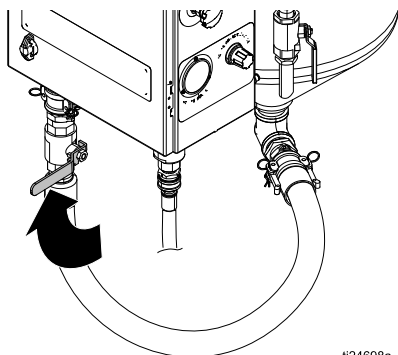

ti24698a

NOTE: If the pot contains water and abrasive (especially under pressure), releasing the cam and groove with the ball valve open will cause an unintentional release of abrasive.

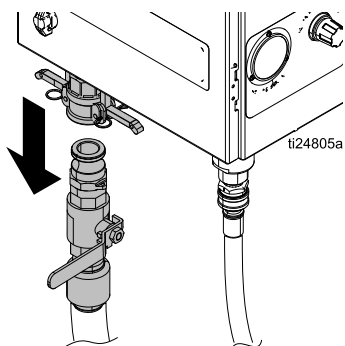

ti24805a

2. Flush water through the pot and out the disconnected abrasive ball valve before filling the pot with water and abrasive.

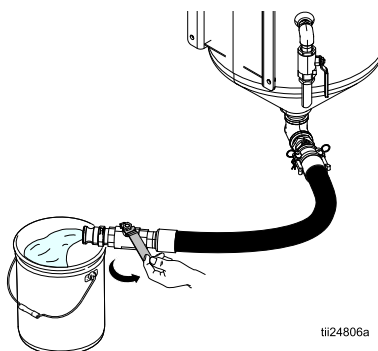

ti24806a

3. Reconnect the abrasive hose.

4. Disconnect the pump inlet hose and flush the water tank to remove any remaining debris. Reconnect the pump inlet hose.
5. Fill the water tank only with fresh water, then open the inlet ball valve.
6. Close the rinse, dump, and abrasive ball valves.

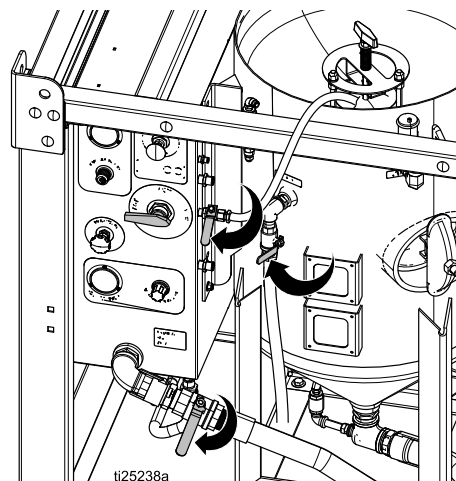

ti25238a

7. Turn the selector valve to RINSE.

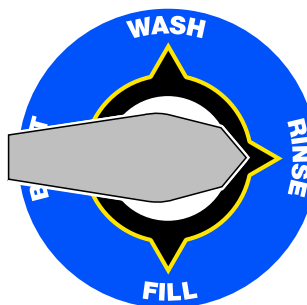

ti24143a

8. Disengage the Emergency Stop.

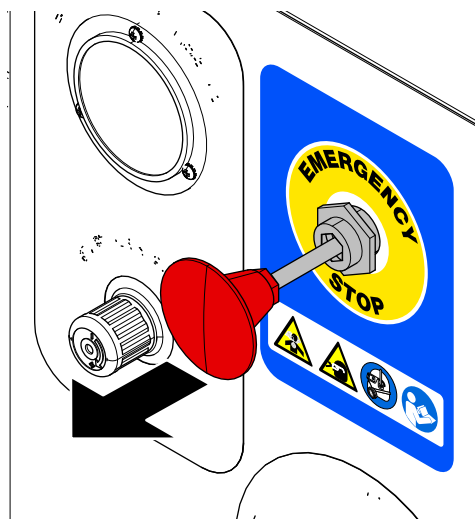

ti24813a

NOTE: The water pump will not work unless the Emergency Stop is disengaged.

Operation

- Align the bung handle with the pin slot, and then firmly push and turn the handle 90° after the pin is below the bracket slot. Proper engagement of the pin will hold the bung down until it is released.

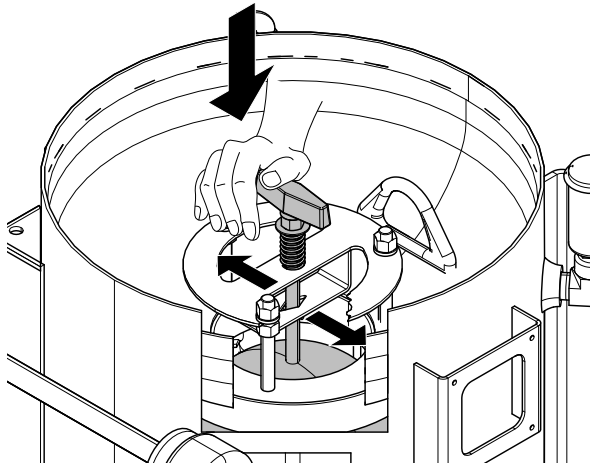

ti24701a

- Add 10 gallons (30 liters) of fresh water to the pot. Wear appropriate personal protective equipment, including an appropriately fit-tested government approved respirator suitable for the dust conditions. Add abrasive material (minimum four bags, maximum ten 50 lb (23 kg) bags of high-mass abrasive, or eight 50 lb (23 kg) bags of low mass abrasive).

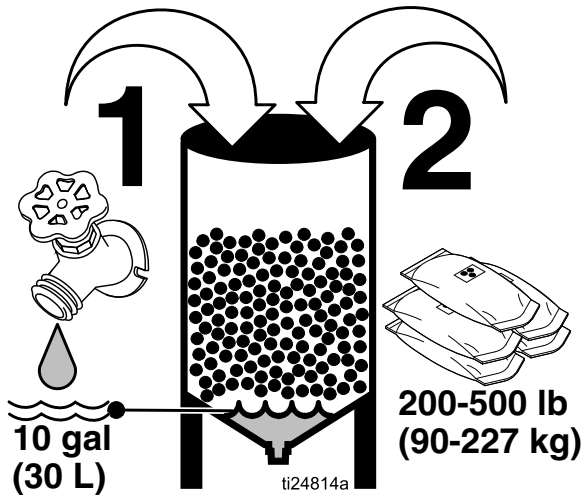

- Use a garden hose or the rinse hose to wash the abrasive into the pot and clear any abrasive from the bung and bung seal.

- When the water level reaches the bung seal, rotate the handle to release the bung pin (this will cause the bung to pop up against the seal and close the bung).

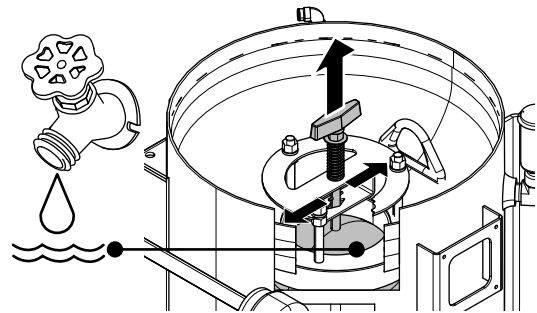

ti24811a

- Turn the selector valve to FILL.

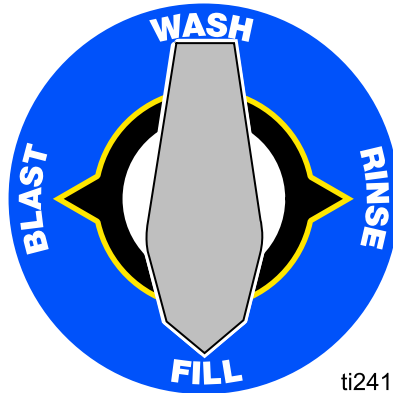

ti24141a

NOTE: The water pump should begin cycling. If not, open the pot pressure regulator enough to cause the pump to run at 60 cpm.

NOTE: The auto vent/purge valve will allow all of the air trapped in the top of the pot to vent. When air stops venting, the pot pressure gauge will start to register pressure.

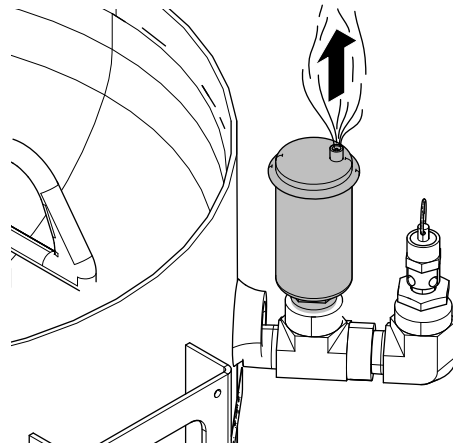

ti24930a

- Wait for pot pressure to increase. **NOTE:** It can take up to several minutes for the pot to pressurize.

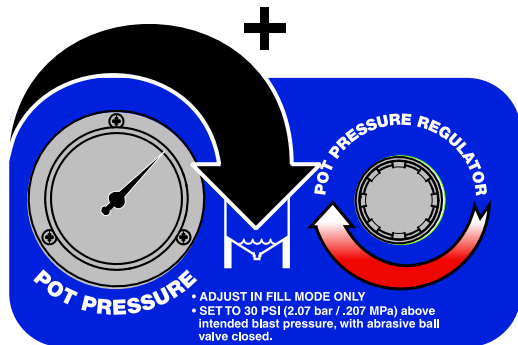

ti24824a

NOTE: The bung cannot be pushed down unless all of the pressure in the pot is released by opening the dump valve.

- Set the pot pressure 30 psi (2.0 Bar, 0.2 MPa) higher than the intended blast pressure. Quickly open and close the dump valve after the pump stalls. Relieve pot pressure to 40 psi (2.7 Bar, 0.27 MPa) before closing the dump valve. Repeat until pot pressure is consistent.
- Turn the selector valve to WASH.
- Set the blast air pressure 30 psi (2.0 Bar, 0.2 MPa) lower than the pot pressure while blasting.

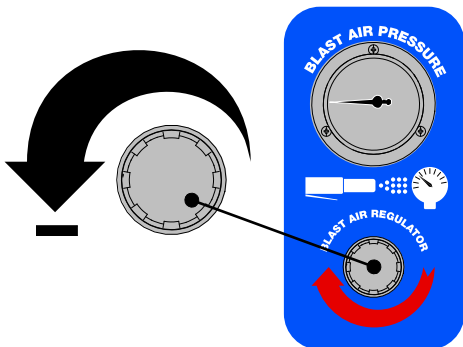

ti24147a

NOTE: In order to adjust the blast pressure, the blast control must be engaged. For the initial setting, leave the abrasive ball valve closed.

NOTE: Engage and release the blast control handle each time the blast regulator is adjusted.

- Turn the selector valve to BLAST.

- Open the abrasive ball valve.

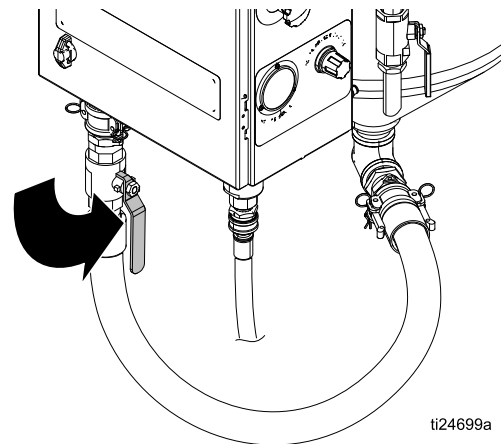

ti24699a

NOTE: Make sure the pot pressure returns to the initial setting (it will not return to the initial setting if the metering valve is closed).

- Engage the blast control switch and begin blasting.

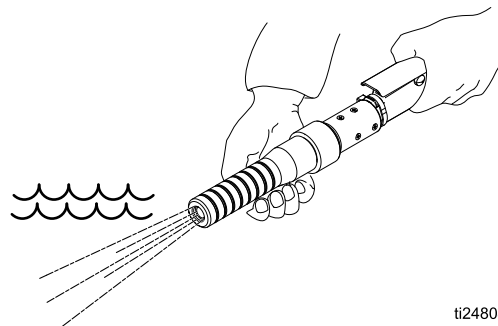

ti24804a

NOTE: You may have to wait 1–2 minutes for the abrasive material to reach the nozzle.

NOTE: Pot pressure and blast pressure should equalize during blasting. Only set pot pressure with the abrasive ball valve closed. Never adjust pot pressure while blasting.

Operation

21. Slowly adjust the abrasive meter valve while the abrasive is blasting from the nozzle. Typical adjustment ranges from 1/8 to 1/4 turn open.

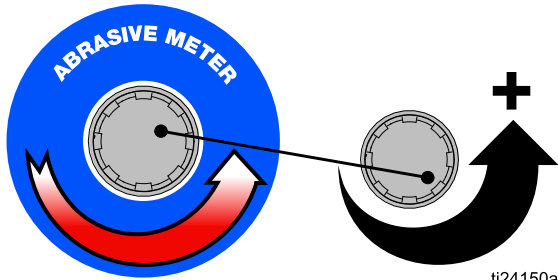

ti24150a

NOTE: The DataTrak can be used to assist in setting the pump cycle rate. Optimal abrasive media consumption typically occurs with the cycle rate set at 7–10 cycles per minute.

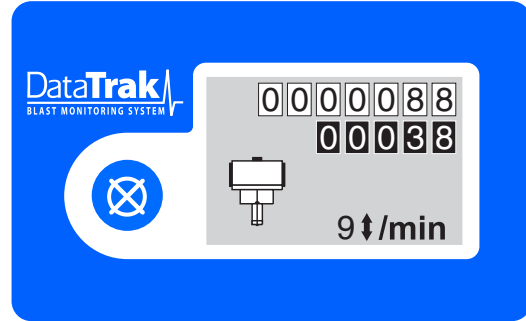

ti24154a

NOTE: Use a piece of test material similar to what you will be blasting.

NOTE: Always start as gently as possible and then increase the blast force as necessary to clean without doing any damage to the substrate. When properly set, the pump should cycle 7-10 times per minute. High production rate users may need to increase cycle rate above 10 cycles per minute.

NOTE: Close the abrasive ball valve whenever you stop blasting for more than 2-3 minutes. This will help to extend the service life of the diaphragm valve.

Blasting Tips

When first learning the effects of the blaster, get a better understanding of the results by starting at a shallow angle (closer to 0° than to 90°) and keep the nozzle approximately 16 in. (40 cm) from the application. Observe the results, then reduce the distance, steepen the angle, and adjust the blast regulator.

As the blast pressure is increased, slowly adjust the metering valve and watch the DataTrak to achieve 7-10 pump cycles per minute. See [DataTrak Controls, page 7](#).

NOTE: The heavier and smaller the abrasive particle (i.e. 80-grit), the more aggressive the results.

Blasting on Higher Surfaces

When blasting on a surface higher than the equipment, make sure that there is a length of blast hose on the ground equal to 10-20% of the height. The hose on the ground prevents unspent abrasive in the hose from back-filling the internal plumbing of the panel.

For example: When blasting 50 feet (15 m) straight up, use at least 10 feet (3 m) of blast hose on the ground before the blast hose goes up to the blasting height.

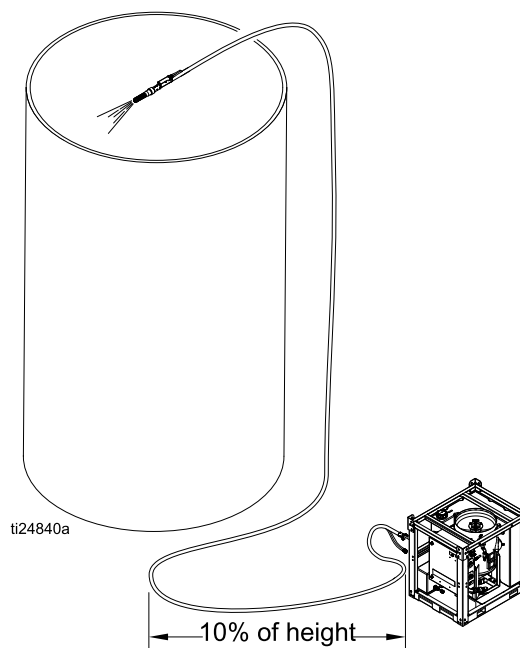

Metering Valve Settings

There is no fixed formula for what works best in each application. The information below works best for the majority of the time. From this initial setting, adjustments can be made up or down to get the fastest removal rates without damage to the surface.

Normal settings are: 110 psi (7.5 Bar, 0.75 MPa) initial pot setting, less than 1/2 turn open metering valve, blasting pressure at 80 psi (5.5 Bar, 0.55 MPa). For applications requiring higher performance, use high-performance abrasive (the heaviest mass @ 80 grit) such as Garnet, and the highest pressures the compressor can support. The initial pot pressure should always be 30 psi (2.0 Bar, 0.2 MPa) above the intended blast pressure.

Gradually make adjustments to meet the specific requirements for each application. Higher blast pressures will require turning the abrasive metering valve slightly more open (and vice versa). Make the adjustments (see [DataTrak Controls, page 7](#)) to achieve 7-10 cycles per minute to be the most efficient (cut at the fastest rate while using the least amount of abrasive). Blasting pressures can range between 30 - 120 psi max (2.0 Bar, 0.2 MPa – 8.2 Bar, 0.82 MPa).

Unlike conventional sandblasting, higher pressures do not necessarily mean better cleaning. Nozzle distance and the angle to the surface has an effect on performance, as does the blast pressure. Choice of abrasive also has a great effect. High-performance abrasive produces the best performance and can save enough time to make up the difference in cost.

NOTE: Blasting with 150+ feet of blast hose requires the use of an electric blast control.

	Grit Size	Blast Pressure	Abrasive Dose	Blast Angle	Notes
General	40/70	60-80 psi (4.1 Bar, 0.41 MPa- 5.5 Bar, 0.55 MPa)	1/4 to 1/2 turns	35° - 65°	When the blast pressure is increased, the abrasive dose turns will also need to be increased.
Wood	80 (using a low mass abrasive like glass)	40-50 psi (2.7 Bar, 0.27 MPa- 3.4 Bar, 0.34 MPa)	1/8 to 1/4 turns	15° - 30°	Do not wash, as it may raise the wood grain. Brush off excess abrasive after the wood dries.
Steel	80-100 (using a high-mass abrasive like Garnet)	100-120 psi (6.8 Bar, 0.68 MPa- 8.2 Bar, 0.82 MPa)	1/4 – 1/2 turns	65° - 85°	When the blast pressure is increased, the abrasive dose turns will also need to be increased.
Fiberglass	40-70 low mass	45-65 psi (3.1 Bar, 0.31 MPa- 4.4 Bar, 0.44 MPa)	1/8 to 1/4 turns	35° - 45°	When the blast pressure is increased, the abrasive dose turns will also need to be increased.

Using the Wash Feature

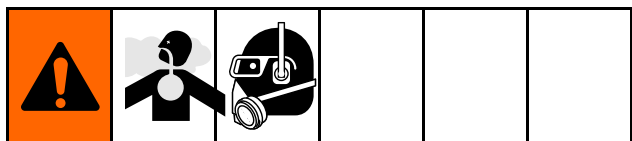

The wash feature causes air-driven water (without abrasive) to blast and rinse areas that have already been blasted with abrasive. It is also a convenient feature for flushing abrasive from the blast hose.

NOTICE

There will always be some residual abrasive in the blast hose. Never use the wash feature on any surface other than where you have blasted, or intend to blast. It will affect/dull the surface.

NOTICE

Do not use the wash feature on wood that has been blasted. It could damage the wood and cause the grain to rise. Wait for the wood to dry and then use a broom, brush, or vacuum to remove any residual abrasive.

1. Close the abrasive ball valve.

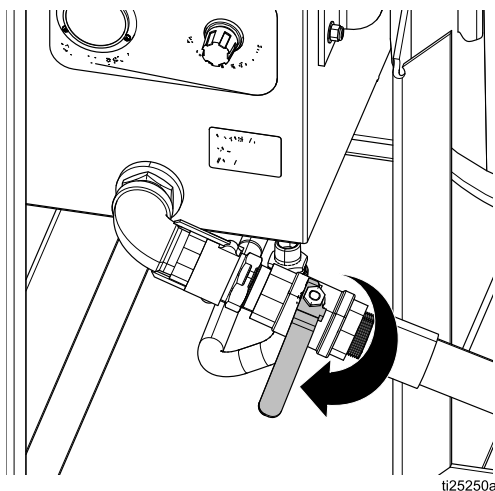

ti25250a

2. Turn the selector valve to WASH.



ti24142a

3. Blast 1 – 2 minutes until the abrasive is cleared from the hose.

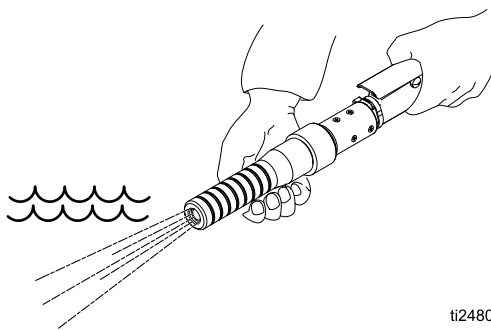

ti24804a

4. The equipment is now ready to wash any previously blasted surfaces.

Refilling the Pot with Abrasive

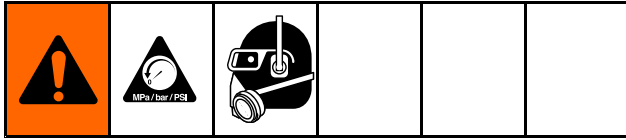

1. Close the abrasive ball valve.
2. Turn the selector valve to RINSE.

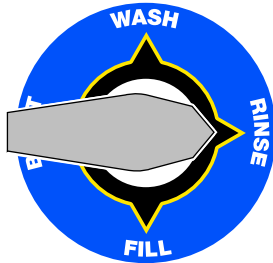

ti24143a

3. Open the dump valve slowly to relieve the water pressure in the pot.

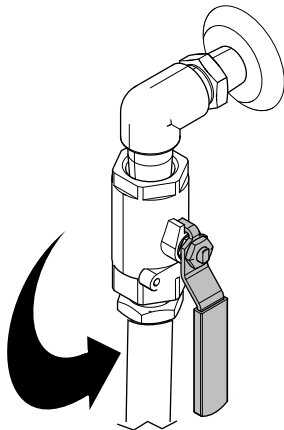

ti24112a

NOTE: Be prepared to capture the water that will be drained from the pot. All disposals must comply with national, state, and local regulations.

4. After all of the pressure in the pot has been relieved, engage the bung pin by compressing the spring and turning the handle 90° to hold the bung in the open position.

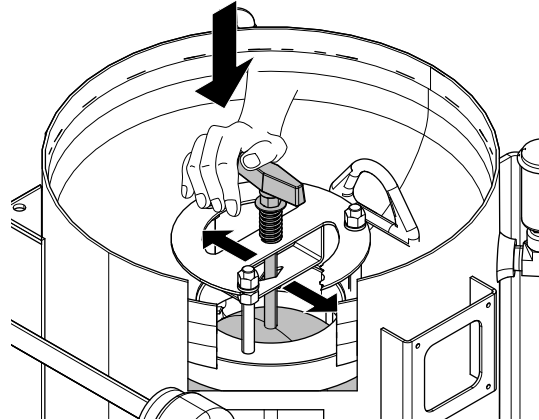

ti24701a

5. Add the abrasive (minimum four bags, maximum ten 50 lb (23 kg) bags of high-mass abrasive or eight 50 lb (23 kg) bags of low-mass abrasive) and continue the procedures from [Setting Up the Equipment, page 11](#).

NOTE: More water may need to be drained from the pot to allow additional abrasive to be added.

Shutting Down

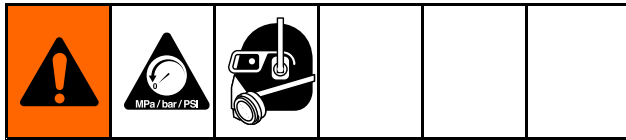

1. When you have finished blasting, perform wash until all of the abrasive is flushed from the blast hose. See [Using the Wash Feature, page 17](#).
2. Turn the selector valve to RINSE, and with the abrasive ball valve closed, continue to blast until water is cleared from the hose. This is to dry the inside of the hose for storage.

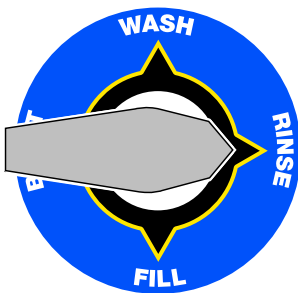

ti24143a

3. Open the abrasive ball valve, then open the dump valve until the pot pressure gauge reads 0 psi. Close the abrasive ball valve and dump valve.

NOTE: Short-term shutdown is now complete. If the unit will be shut down for more than 24 hours, proceed to the next step.

4. Disconnect the abrasive ball valve cam-lock by removing the coupler pins and pulling the rings out and up to pull the two cams away from the groove.

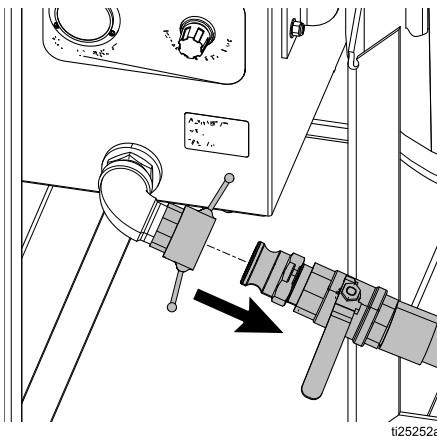

ti25252a

5. Hold a bucket under the cam-lock coupler, then turn the selector valve to WASH. This will clean debris from the cam-lock coupler and gasket.

NOTE: Make sure the gasket is in place after the procedure.

NOTE: Be sure to catch the unspent abrasive that will be washed out of the panel plumbing and out of the groove fitting.

6. Turn the selector valve to FILL. This will help push the abrasive out through the abrasive hose.
7. Place a bucket under the abrasive hose. Slowly open and close the abrasive ball valve to flush abrasive material from the pot. Repeat several times. Once no abrasive material flows from the hose, close the abrasive ball valve.

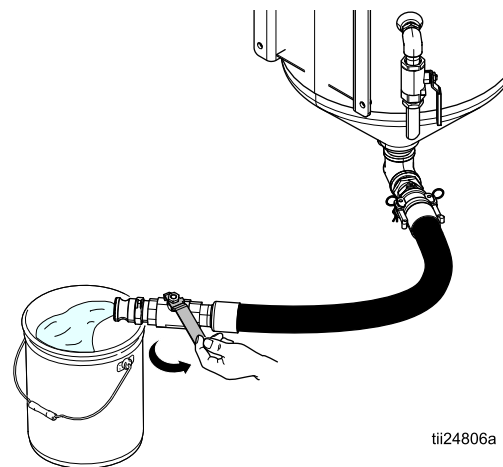

ti24806a

NOTE: Estimate that a 5 gallon pail will be needed for each bag of abrasive still in the pot. Cover the buckets during storage so debris does not contaminate the abrasive.

Operation

- Engage the bung pin to hold the bung open and allow air to enter.

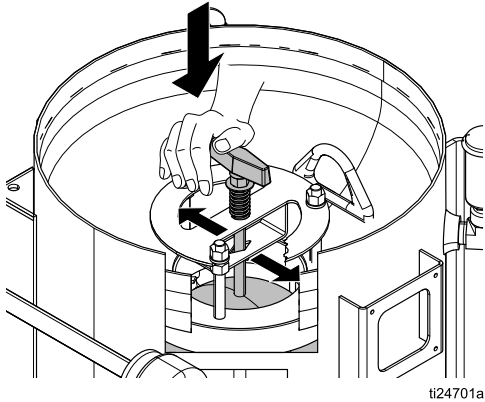

ti24701a

- Open the abrasive ball valve and flush the pot of any remaining abrasive material.

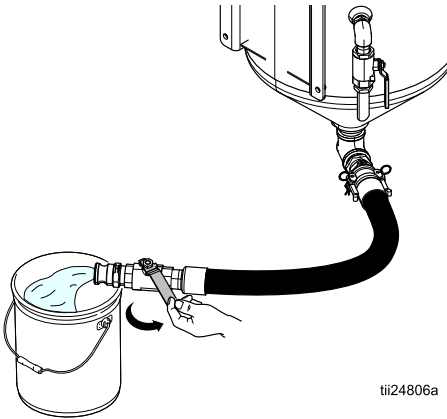

tii24806a

- Close the pot bung and connect the abrasive hose. Relieve pressure to complete system shutdown (see [Pressure Relief Procedure, page 8](#)).

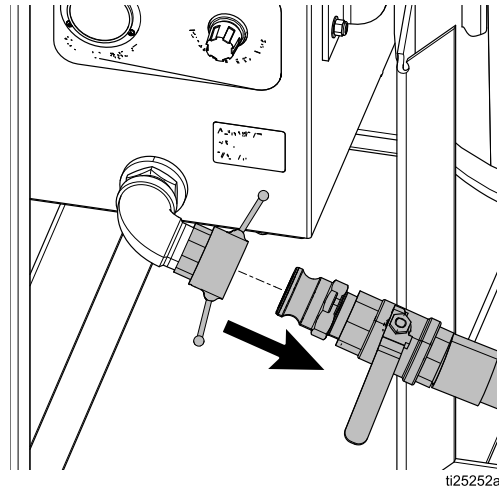

ti25252a

NOTE: The system must be winterized if it will be exposed to temperatures below freezing. See [Winterizing the Equipment, page 21](#).

Winterizing the Equipment

Vapor-Abrasive Blasters must be winterized whenever there is a possibility of freezing temperatures during storage. It is imperative that you anticipate the possibility of a freeze and always protect the unit during fall and winter seasons, even if being stored only overnight.

1. Make sure all of the water has been drained from the pot. Reconnect the abrasive hose after draining the pot.

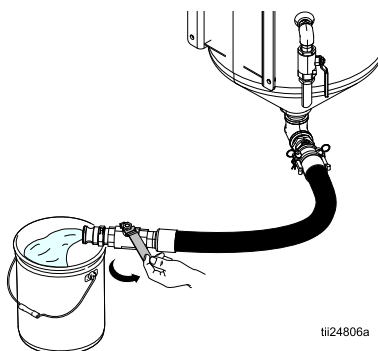

ti24806a

2. Make sure the pot bung is in the closed position. This will prevent debris from entering the pot during storage.
3. Drain the water tank by disconnecting the pump inlet hose and opening the inlet ball valve.

NOTE: All disposals must comply with national, state, and local regulations. In addition, if the water contains a rust inhibitor, you may want to retain and preserve the water due to the expense of the inhibitor.

4. Drain the pump inlet hose, then insert the end into a windshield wash container. Choose a windshield wash with a rating that will protect the equipment for the lowest temperatures in your area.

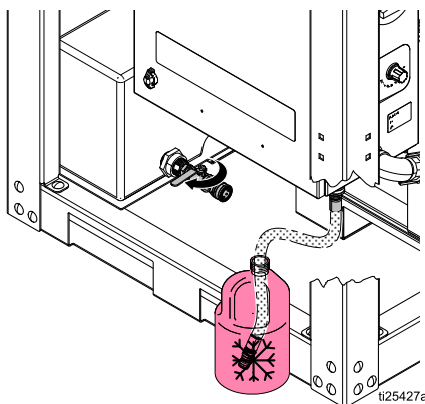

ti25427a

5. Turn the selector valve to RINSE and open the rinse ball-valve. While holding the rinse hose over the pot, run the pump until windshield wash comes out of the rinse hose.

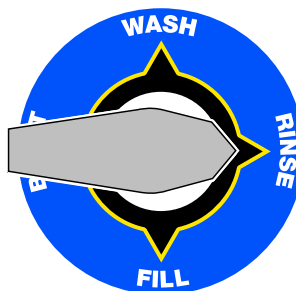

ti24143a

6. Move the selector valve into the other three positions (WASH, BLAST, and FILL). Confirm that the internal water tubing fills with windshield wash before turning the selector valve to the next position.

NOTE: All 3/8 in. tubing should be filled with windshield wash for full protection.

7. Engage the E-Stop.
8. Reconnect the pump inlet hose to the inlet ball valve.
9. Add 1–2 gallons (4–8 liters) of windshield wash to the water tank. Make sure that the rinse ball-valve and the drain ball-valve are left open.

NOTICE

When ice forms behind the seals, the seals can become damaged. During storage, position all ball-valves in the open position.

Troubleshooting

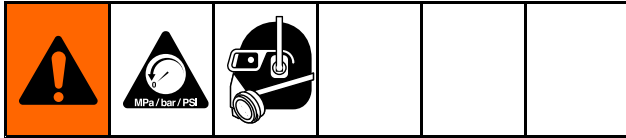

Problem	Cause	Solution
The pot will not properly pressurize.	The air supply is inadequate.	Make sure the air inlet pressure gauge reads 100-125 psi. If the gauge does not read 100–125 psi, check the air compressor for proper setup.
	The Emergency Stop is engaged.	Disengage the Emergency Stop.
	Inadequate water supply to the pump.	Make sure the water tank is full and the inlet ball valve is open.
	The pot pressure regulator is set too low.	Increase the setting on pot pressure regulator.
	The pot bung cannot seal properly.	Clean all abrasive from the bung and seal. Make sure the bung spring is lifting and the bung is firmly against the seal. If cleaning does not solve issue, replace bung seal.
	The Auto-Vent valve will not seal.	See Cleaning the Auto-Vent Valve, page 31 .
	The pot pressure relief valve is discharging water.	Decrease the pot pressure to 145 psi (10.3 bar, 1.03 MPa) or less. If the valve weeps or relieves at 145 psi, replace valve (Kit 17D785).
	The pot or pump is leaking pressure.	Make sure the abrasive ball valve and the dump valve are closed. If pot pressure gauge still creeps downward. See Checking for Leaks, page 26 .
The pot pressure regulator is malfunctioning.	The pot pressure regulator is malfunctioning.	Replace the pot pressure regulator assembly (17C132).
The blast pressure will not reach the desired set point.	The air supply is inadequate.	Make sure the air inlet pressure gauge reads 100-125 psi. If the gauge does not read 100–125 psi, check the air compressor for proper setup.
	The main air regulator is malfunctioning.	See Repairing the Main Air Regulator, page 28 (EQ600 – Kit 17C131, EQ300 – Kit 17C129).
	The blast air regulator is malfunctioning.	Replace the blast air regulator (Kit 17C625).

Problem	Cause	Solution
<p>No abrasive flows from the nozzle during blast mode.</p>	<p>The pot does not have a sufficient amount of abrasive.</p>	<p>See Refilling the Pot with Abrasive, page 18.</p>
	<p>The system is not properly set up.</p>	<p>See Setting Up the Equipment, page 11. Make sure the pot pressure is properly set. The pot pressure must be set 30 psi above the blast pressure. Make sure the selector valve is set to BLAST. The abrasive ball valve must be open. The abrasive metering valve must be at least 1/8 turn open.</p>
	<p>There is an obstruction in the media circuit.</p>	<p>See Flushing the Diaphragm Valve, page 29.</p>
	<p>The diaphragm valve is not working.</p>	<p>See Repairing the Diaphragm Valve, page 30.</p>
	<p>There is blockage inside the pot or inside the abrasive hose between the pot and the panel.</p>	<p>Make sure the ball valve is closed, then disconnect the cam-lock coupler. Open the abrasive ball valve slightly and make sure abrasive is flowing from the abrasive hose. If not, follow the shut down procedure (see Shutting Down, page 19). Thoroughly flush the pot and the media hose after draining media and water.</p>
<p>No blast air flow when the blast control is engaged. The water pump cycles while the blast control engaged.</p>	<p>The blast regulator is not adjusted to the correct pressure.</p>	<p>Adjust the blast regulator to the desired pressure while the blast control is engaged.</p>
	<p>The tubing from the main air regulator is not properly connected.</p>	<p>Confirm that the tubing from the blast regulator to the main air regulator is intact. See Hose Schematic, page 42.</p>
	<p>The blast air regulator is malfunctioning.</p>	<p>Replace the blast air regulator (Kit 17C625).</p>
	<p>The main air regulator is malfunctioning.</p>	<p>See Repairing the Main Air Regulator, page 28 (EQ600 – Kit 17C131, EQ300 – Kit 17C129).</p>
<p>No blast air flow when the blast control is engaged. The water pump does not cycle while the blast control engaged.</p>	<p>The air supply is inadequate.</p>	<p>Make sure the air inlet pressure gauge reads 100-125 psi. If the gauge does not read 100–125 psi, check the air compressor for proper setup.</p>
	<p>The Emergency Stop is engaged.</p>	<p>Disengage the Emergency Stop.</p>
	<p>The electric blast control circuit is malfunctioning.</p>	<p>Inspect the hose cable for damaged or shorted wiring. Check the battery and control panel connections. Make sure the DC power source is 12V. Check the 3A fuse inside the control panel, and replace it if necessary. Check the current flow in the circuit. If current exists, replace the relay (EQ5179).</p>

Troubleshooting

Problem	Cause	Solution
	The pneumatic blast control circuit is malfunctioning.	See Pneumatic Blast Control Circuit, page 27 .
The blast control is not engaged but blasting still occurs.	The main air regulator is stuck open.	See Repairing the Main Air Regulator, page 28 (EQ600 – Kit 17C131, EQ300 – Kit 17C129).
	The blast control tubing is not connected properly.	Ensure air tubing is routed and connected properly. See Hose Schematic, page 42 .
	Electric blast control circuit is malfunctioning.	Inspect hose cable for damaged or shorted wiring. Check battery and control panel connections. Ensure DC power source is 12V. Check 3A fuse inside control panel and replace it if necessary. Check current flow in circuit, if current exists, replace relay (EQ5179).
	Pneumatic blast control circuit is malfunctioning.	See Pneumatic Blast Control Circuit, page 27 .
The blast spray pattern is irregular.	Incorrect abrasive is being used.	Use the correct abrasive. See Metering Valve Settings, page 16 .
	The pot does not have a sufficient amount of abrasive.	Refill the pot with abrasive. See Refilling the Pot with Abrasive, page 18 .
	The pot pressure setting is incorrect.	Perform the pressure relief procedure (see Pressure Relief Procedure, page 8) and reset pot pressure (see Setting Up the Equipment, page 11).
	The Auto-Vent valve does not vent air when the pot is filled.	Make sure the Auto-Vent valve is working. Perform the Auto-Vent cleaning procedure (see Cleaning the Auto-Vent Valve, page 31).
	The diaphragm valve is malfunctioning.	Perform the diaphragm flush procedure (see Flushing the Diaphragm Valve, page 29). If flushing does not solve problem, see Repairing the Diaphragm Valve, page 30 .
	There is blockage inside the pot or inside the abrasive hose between the pot and the panel.	Make sure the ball valve is closed, then disconnect the cam-lock coupler. Open the abrasive ball valve slightly and make sure abrasive is flowing from the abrasive hose. If not, follow the shut down procedure (see Shutting Down, page 19). Thoroughly flush the pot and the media hose after draining media and water.

Problem	Cause	Solution
A strong hose recoil occurs frequently when the blast control switch is engaged.	The unit is not on a level surface.	Place the unit on a level surface. If this is impossible, the Auto-Vent must be on the higher side of the unit.
	The initial pot pressure is not set correctly.	Confirm that the auto-vent valve is working and set initial pot pressure 30 psi (2.0 bar, 0.20 MPa) above the blast pressure.
	The Auto-Vent is malfunctioning.	Perform auto-vent cleaning procedure (see Cleaning the Auto-Vent Valve, page 31).
	The diaphragm needs to be flushed.	Perform the diaphragm flush procedure (see Flushing the Diaphragm Valve, page 29). If flushing does not solve the problem, see Repairing the Diaphragm Valve, page 30 .

Troubleshooting Examples

Checking for Leaks

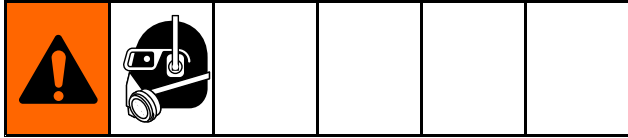

1. Open the dump valve. Check pot pressure gauge, then close the dump valve.

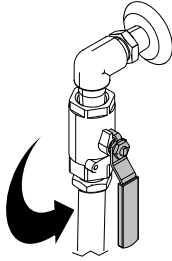

ti24112a

Look at the pressure gauge to confirm that all pressure has been relieved from the pot.



ti24825a

2. Disconnect the tubing at the blast check valve (L) and at the fill port check valve (ZG).

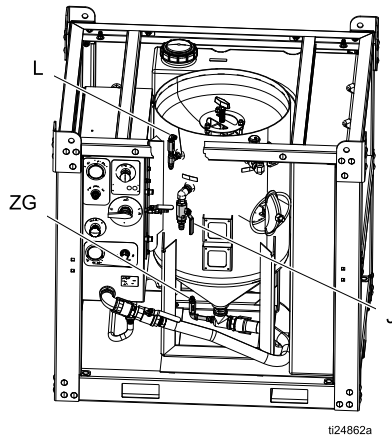

ti24862a

3. Make sure the bung is engaged with its seal. Turn the selector valve to WASH, then open the abrasive ball valve to pressurize the pot. Set the pot pressure to 145 psi (9.9 Bar, 0.99 MPa).



ti24142a

4. Check the water pump to confirm that no water is leaking from the TSL fill port.

NOTE: The pump should stall after the pot pressurizes. If the pump does not stall, replace the seals. Refer to the pump manual for repair information.

5. Check for any water leaking from either check valve. If a check valve is leaking, it must be repaired or replaced. If the valves are damaged, the pot will not be able to maintain pressure. Also, check the pot pressure relief valve. If the valve is weeping at pot pressures of 145 psi or less, it needs to be replaced.
6. Close the abrasive ball valve, then disconnect the quick coupler and confirm that the ball valve is not leaking. Replace the abrasive ball valve if it is leaking.

Pneumatic Blast Control Circuit

1. At the Air-Relay, disconnect the push-to-connect tubing and check the trigger circuit (from the blast control handle).

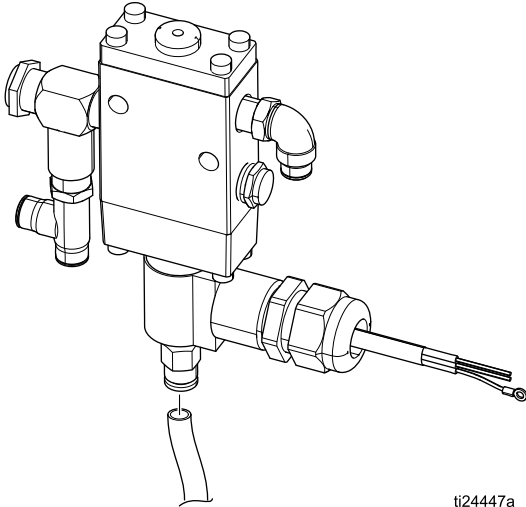

2. With the blast control activated, confirm that there is air flowing from the disconnected tube.

NOTE: The air flow should be at supply air pressure but the air volume is reduced due to the size of the fittings and tubing. If you do not get supply air pressure, check the blast control handle for proper operation, and check the blast control hoses to make sure they are not kinked or internally blocked.

3. Check the in-line filter at the industrial interchange nipple connection on the side of the panel (where you attach the blast control hose).
4. If the previous steps do not fix the issue, replace the air relay (Kit EQ5179).

Repair

Repairing the Main Air Regulator

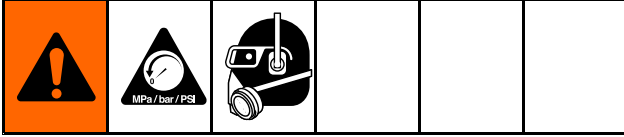

NOTE: Repair parts are available in Kit 17C131 (EQ600) or Kit 17C129 (EQ300).

1. Perform [Pressure Relief Procedure, page 8](#).
2. Make sure all of the air pressure is relieved in the unit. Remove the water separator filter for access to the piston cover and return spring.
3. Use a crescent wrench that can open to 2 in. (5 cm) to unscrew the piston cover.

NOTE: There is a spring inside this cover.

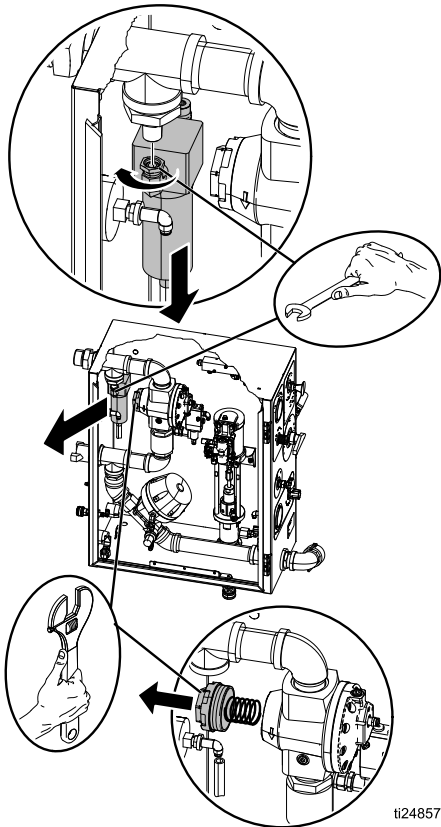

ti24857a

4. Unscrew the diaphragm cover for access to the diaphragm and to the end of the piston shaft.

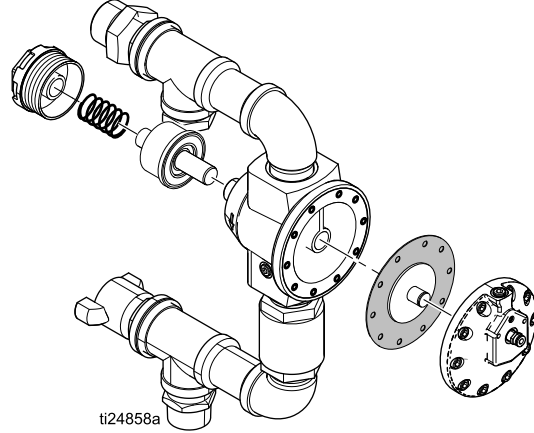

ti24858a

5. Remove the diaphragm and inspect for any cracks or tears. Replace the diaphragm if necessary.
6. Carefully remove the spring and piston assembly, then clean out any debris in the body of the regulator.
7. Push the piston shaft and remove the piston from the opposite end of the regulator housing.
8. Inspect the piston for any foreign matter that may have been the cause for the piston to stay open.
9. Inspect for any damage to the piston shaft where it interacts with the diaphragm cup.

NOTE: Excessive wear here indicates the main check valve is not sealing. Contact your distributor if this happens.

Flushing the Diaphragm Valve

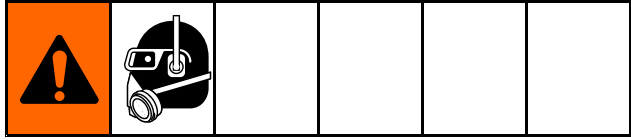

This procedure can be performed with the component still mounted in the panel.

If large-grit abrasive or other foreign matter become lodged in the diaphragm valve, it will become necessary to flush the valve. This is a simple procedure; however, it does cause the release of a large volume of air to escape through the released quick coupling. You need to be prepared for the release of air by pulling the quick coupler grommet out of its groove so that it does not get lost.

1. Operate the unit in WASH (see [Using the Wash Feature, page 17](#)) until all abrasive clears from the blast hose.



ti24142a

2. Close the abrasive ball valve, then turn the selector valve to RINSE.

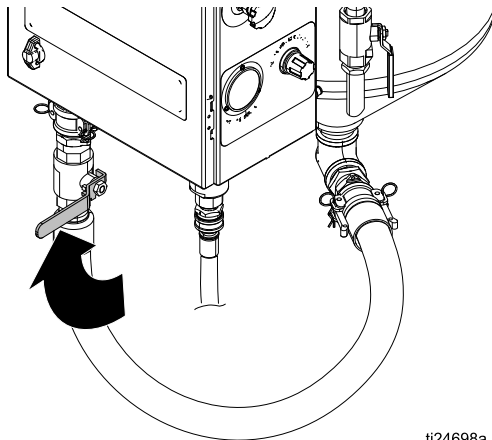

ti24698a

3. Disconnect the quick coupling at the abrasive ball valve (not at the bottom of the pot).

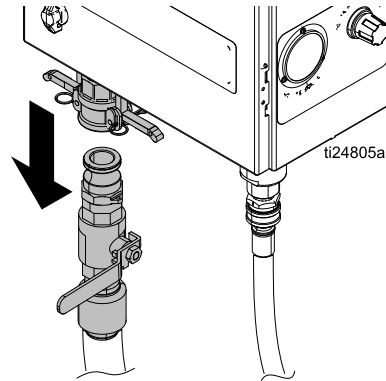

4. Turn the selector valve to WASH. This will pump water out of the quick coupler and allow you to reach up inside and clear all abrasive and remove the grommet.
5. Make sure nothing is in the path of the open quick coupler, then engage the blast control briefly and several times.

NOTE: High flow air should escape through the cam-lock coupling. If this does not occur, the diaphragm valve is malfunctioning. Replace entire diaphragm canister (EQ5140 – EQ600, EQ5142 – EQ300).

6. Hold the male end of the quick coupler up to the water coming from the cam-lock end of the coupler. Clean off any dirt or abrasive.
7. Turn the selector valve to RINSE to stop the flow of water.
8. Re-insert the grommet into its internal groove inside the cam-lock.
9. Reconnect the quick coupler. If properly cleaned and connected, there should be no leaks at the coupler during operation.

Repairing the Diaphragm Valve

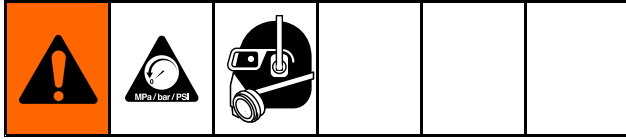

NOTE: The diaphragm (17C127 – EQ300, 17C128 – EQ600) can be replaced without removing the assembly from the panel. You will need an 8 mm Allen wrench for the EQ600S and a 6 mm for the EQ300S.

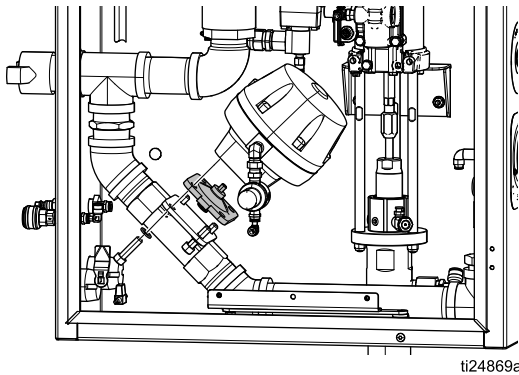

ti24869a

1. Perform the [Pressure Relief Procedure](#), page 8 .
2. Loosen all 4 Allen-head cap-bolts evenly and then remove them completely while supporting the canister of the diaphragm valve.

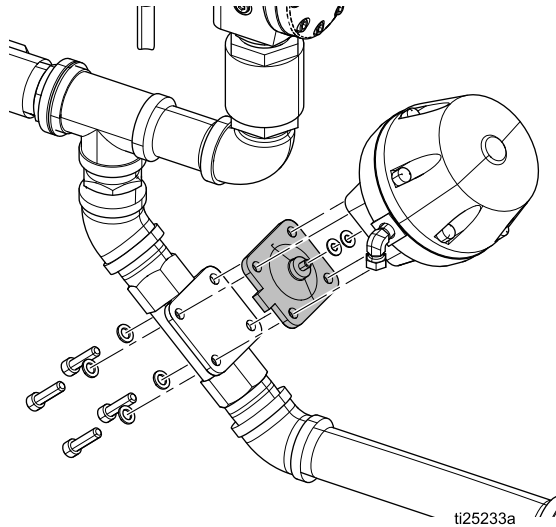

ti25233a

3. Replace the diaphragm (natural rubber compound) and hand-tighten it as far as possible to establish the alignment with the canister.

NOTE: There are two shims between the diaphragm and the actuator. Keep the shims and reuse them (they do not come with the replacement diaphragm). Do not cause any pre-load or torque on the diaphragm by over-tightening it in a misaligned position.

4. Insert all 4 Allen-head cap bolts but do not tighten them.
5. Apply more than 80 psi (5.5 Bar, MPa) air pressure to the regulator inlet to cause the piston to retract.
6. With the piston retracted, hand-tighten the 4 Allen-head cap bolts.
7. Release the air pressure.
8. Tighten the cap-bolts in an alternating pattern (see image below) to 80 +/- 8 in-lb (9 +/- 0.9 N•m). This will cause a slight bulge in the diaphragm between the canister and the stainless steel casting.

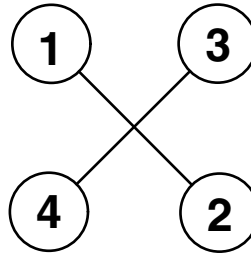

ti25234a

9. Test and confirm that the unit is working properly.

NOTE: This can be done using only water to charge the equipment – there is no need to use abrasive for this test.

Cleaning the Auto-Vent Valve

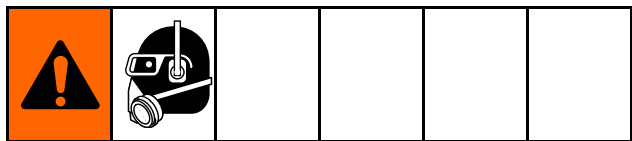

After the pop-up has been closed while filling the pot, the auto-vent valve should release air (you should be able to hear the air venting).

The pot pressure gauge will not show pressure until the auto-vent valve has bled all of the air and sealed. If the auto-vent valve does not release air, or if water leaks from the stem during the fill process, the stem valve may be clogged or faulty.

Perform the following procedure to clean a clogged auto-vent valve.

1. Try to push and quickly release the valve with your finger. If that does not cause the valve to seal, open the dump valve to release all of the pressure in the pot.
2. Turn the selector valve to RINSE.

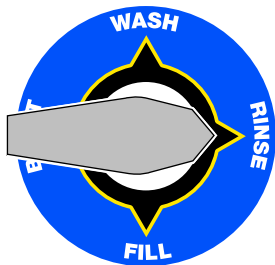

ti24143a

3. Use the rinse hose to force water backwards into the valve stem.

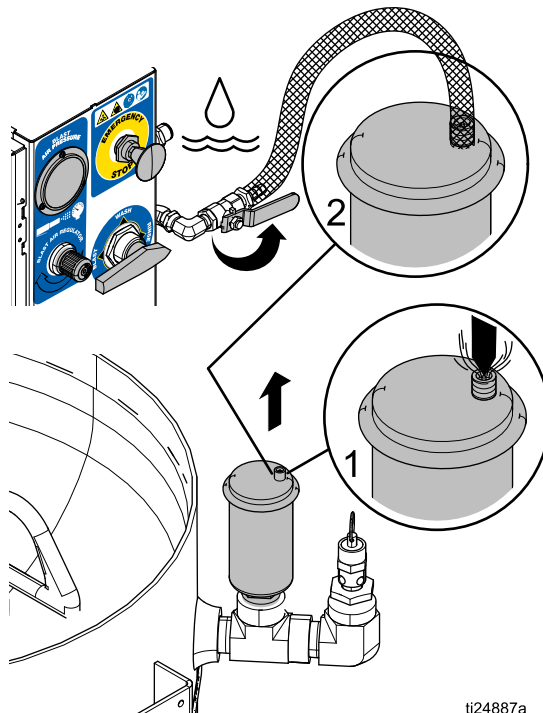



ti24887a

NOTE: If the previous steps fail to resolve the issue, replace the whole valve assembly (EQ1860).

NOTICE

The valve stem itself is internally attached to the float and it is not field-serviceable. Do not try to remove the valve stem. Damage to the equipment will occur.

Replacing the DataTrak Battery

					
FIRE AND EXPLOSION HAZARD					
To reduce the risk of fire and explosion, the battery must be replaced in a non-hazardous location.					
Use only an approved replacement battery (see table). Use of an unapproved battery will void Graco's warranty.					

Replace Battery

1. Unscrew cable from the back of the reed switch assembly.
2. Remove the cable from the two cable clips.

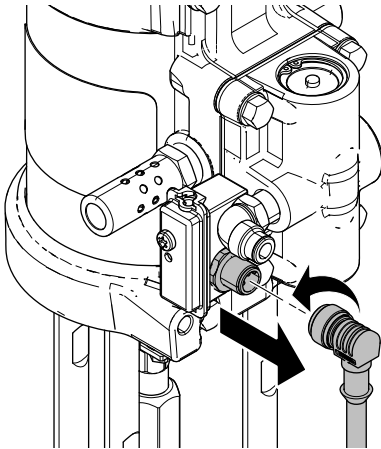

ti24946a

3. Remove the DataTrak module from the bracket. Take the module and attached cable to a non-hazardous location.

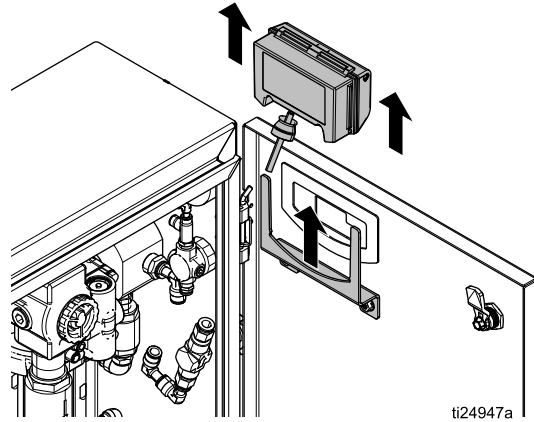

ti24947a

4. Remove the two screws on the back of the module to access the battery.
5. Disconnect the used battery and replace it with an approved battery.

Approved Batteries
Energizer alkaline #522
Varta alkaline #4922
Ultralife lithium #U9VL
Duracell alkaline #MN1604

Replacing the DataTrak Fuse

FIRE AND EXPLOSION HAZARD					
To reduce the risk of fire and explosion, the fuse must be replaced in a non-hazardous location.					
Use only an approved replacement fuse (see table). Use of an unapproved fuse will void Graco's warranty.					

Replace Fuse

1. Remove the screw, metal strap, and plastic holder.
2. Pull the fuse away from the board
3. Replace with an approved fuse.

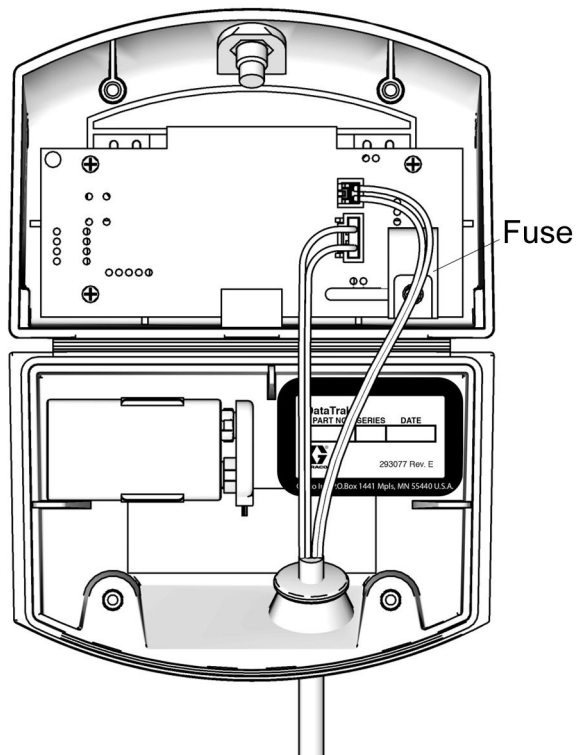

Approved Fuses		
DataTrak Part Number	*Series Letter	Fuse Required
289822	A or B	24C580
	C and later	24V216
All other part numbers	A	24C580
	B and later	24V216

Parts

EQ200T and EQ400T Parts List

EQ200T and EQ400T

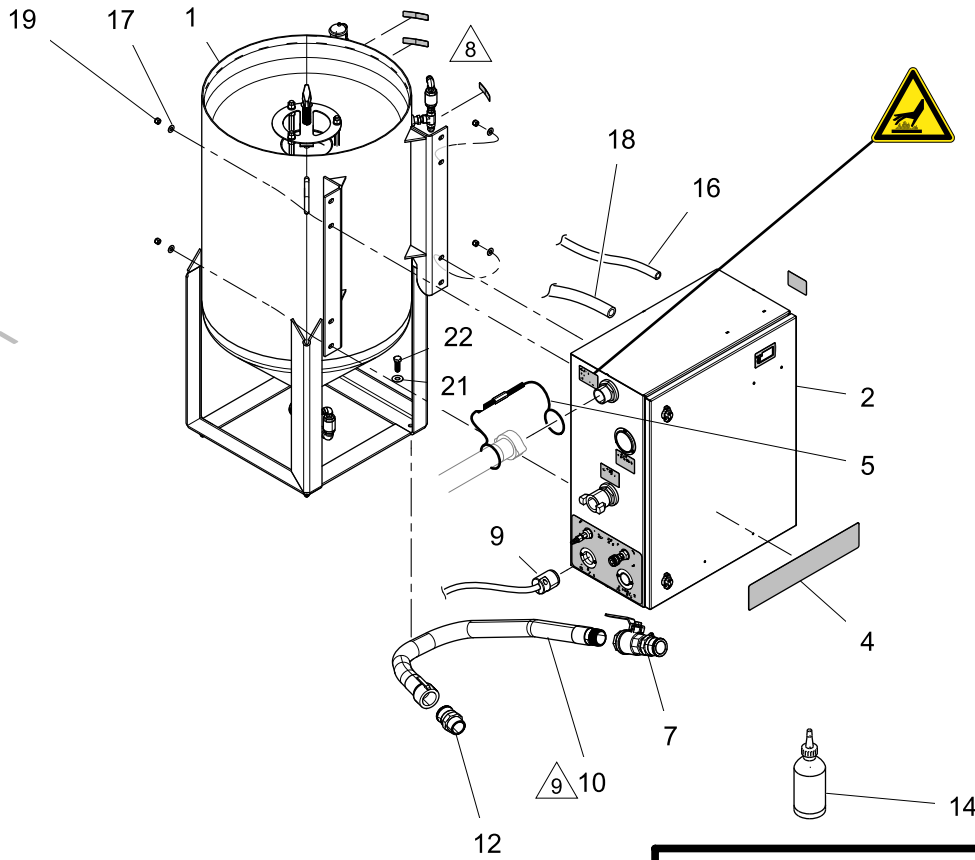

ti24932a

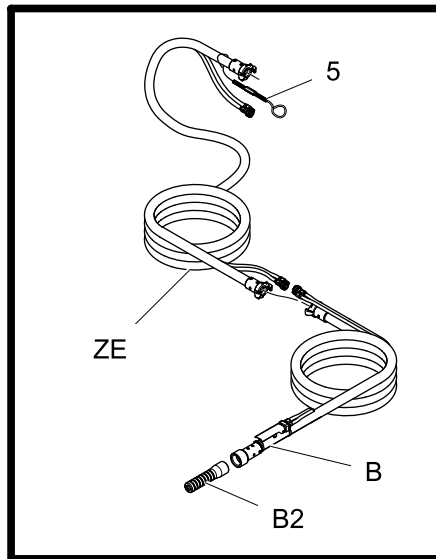

Ref.	Part	Description	Qty.	Ref.	Part	Description	Qty.
1		PRESSURE POT, 6.5 cf, assy	1			EQ200T Models	
2		ENCLOSURE, blast	1			EQ400T Models	

Ref.	Part	Description	Qty.	Ref.	Part	Description	Qty.
4		LABEL, branding	1		EQ5208	EQ400T Models	
5	17D786	KIT, replacement, hose restraint	1	12		ADAPTER, cam groove, type F, ss	1
	17D787	KIT, replacement, coupler pin			EQ1934	EQ200T Models	
7		VALVE, abrasive, media	1		EQ1046	EQ400T Models	
	EQ5149	EQ200T Models		14	206994	FLUID, TSL, 8 oz. bottle	1
	EQ5135	EQ400T Models		16	EQ1881	HOSE, tubing, natural, 1/4 in.	2
9	EQ5183	CABLE, cord, electric, blast control	1	17	111743	WASHER, flat	4
				18	EQ1273	HOSE, tubing, natural, 3/8 in.	4
				19	EQ1151	NUT, nylok, ss, 3/8-16	4
10		HOSE, abrasive media	1	22	EQ1519	BOLT, hex head, ss, 1/2-13 x 1-1	4
	EQ1943	EQ200T Models					

Enclosure

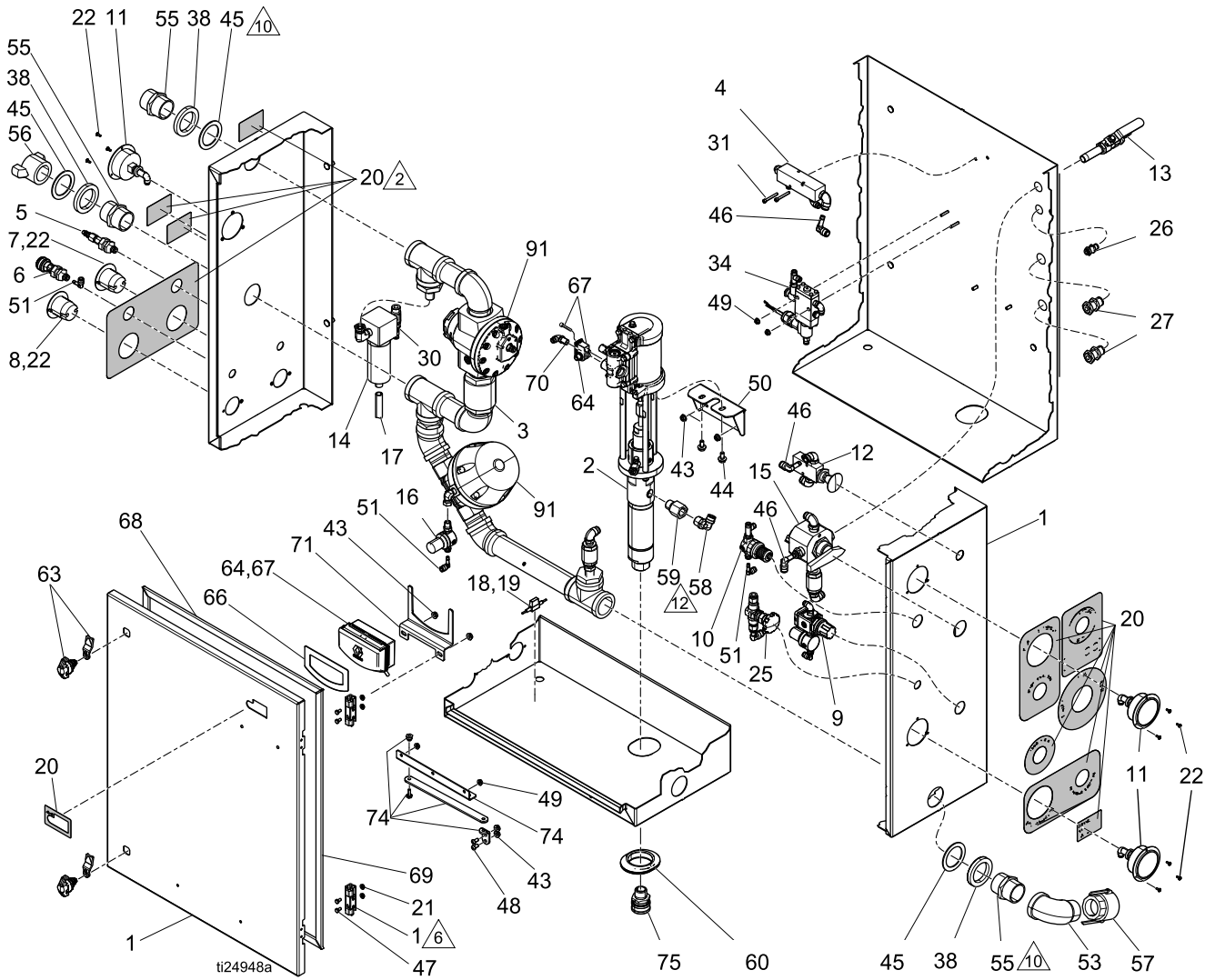

 Torque fitting to 35 – 40 ft-lb (47 – 54 N•m).

Enclosure Parts List

Ref.	Part	Description	Qty.	Ref.	Part	Description	Qty.
1		ENCLOSURE, ss, el, 30 in. x 24 in. x 12 in.	1	47	111639	SCREW, cap, hex, hd	4
2	24V672	PUMP, water, sst, 3:1	1	48	111831	SCREW, cap, skt, button hd	2
3		KIT, blast plumbing	1	49	127908	NUT, flange, serrated, #10-32, ss	4
4	EQ5109	KIT, manifold	1	50		BRACKET, pump	1
5	EQ5112	KIT, blast control, return	1	51	EQ1121	FITTING, elbow, stem, 1/4 in.	3
6	EQ5113	KIT, blast control, output	1	53		FITTING, elbow, street, 90 degree, not, ss	1
7	EQ1790	PLUG, flanged inlet, twist-lock	1	55		FITTING, nipple, hex, not, ss, 1.5 in.	3
8	EQ1791	CONNECTOR, flanged inlet, twist-lock	1	56		COUPLER, sandblast, tank, brass	1
9	17C132	REGULATOR, pump	1	57		COUPLER, cam, lock, type D, ss, 1.5 in.	1
10	17C625	REGULATOR, blast, 125 psi	1	58		FITTING, elbow, push-to-connect, 1/2 in.	1
11	17C133	KIT, gauge and fitting	3	59		FITTING, adapter	1
12	EQ5108	KIT, E-stop, 3/8 in. npt	1	60	17B912	GROMMET, pump, mounting	1
13	EQ5125	VALVE, rinse, 3/8 in. npt	1	63	17D685	KIT, replacement, door latch	2
14	EQ5110	KIT, air filter, 3/8 in. tube	1	64	122030	CABLE, GCA, M12-5P	1
15	EQ5181	VALVE, selector, 5-way	1	66		GASKET, EcoQuip, enclosure	1
16	EQ5119	REGULATOR, fixed, 80 psi	1	67	24A592	KIT, smarts, cycle count only	1
17	EQ1840	HOSE, clear, braided, 3/8 in. ID	2	68		GASKET, EcoQuip, enclosure	2
18	EQ1527	FITTING, holder, fuse, ATM type	1	69		GASKET, EcoQuip, enclosure	2
19	EQ1844	FUSE, ATM, blade type, 3 amp	1	70	121022	FITTING, elbow, male, 1/4 npt	1
▲20	17B751	LABEL, safety	1	71		BRACKET, EcoQuip, DataTrak	1
21	127918	NUT, flange, serrated, m5	4	74	17D686	DOOR, stay	1
22	127929	SCREW, sems, #6-32, 3/8 in. sst	13	75	EQ1846	COUPLER, interchange, straight	1
25	EQ5160	VALVE, needle, dose	1	90		KIT, repair, externally piloted air regulator	1
26	125420	FITTING, bulkhead, M14 x 1/4 tube	1		17C129	EQ200T	
27	EQ1115	BULKHEAD, connector, union 3/8 in.	2		17C131	EQ400T	
30	EQ1759	FITTING, stem, reducer, 1/4 in. x 1/4 in. tube	1	91		KIT, repair, diaphragm valve	1
31	127932	SCREW, sems, #10-32, 1.5 in. sst	2		17C127	EQ200T	
34	EQ5179	RELAY, air pilot, blast control	1		17C128	EQ400T	
38		SPACER, blast circuit, 1.5				Diaphragm valve, full canister	
43	127917	NUT, flange, serrated, 1/4-20 ss	6		EQ5140	EQ200T	
44	111799	SCREW, cap, hex, hd	2		EQ5142	EQ400T	
45		SPACER, washer, shim, ss					
46	EQ1122	FITTING, elbow, stem, 3/8 in.	3				

▲ Replacement Danger and Warning labels are available at no cost.

Trailers

EQ200 Trailers

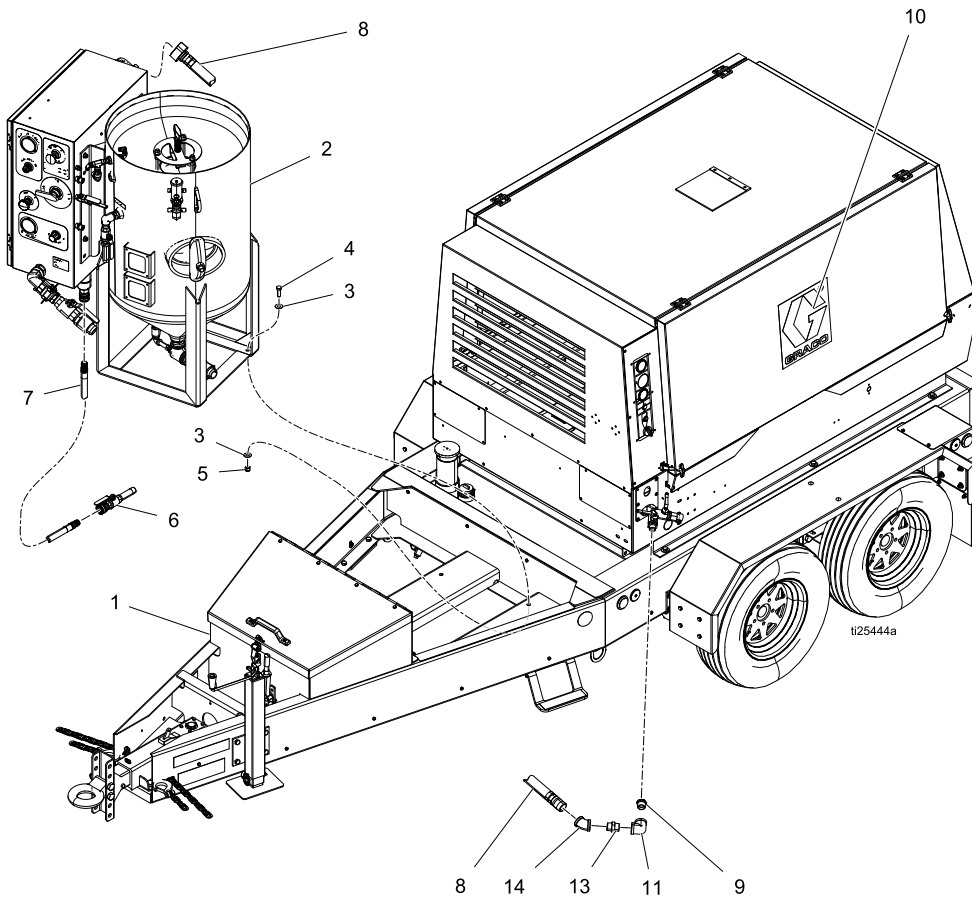

EQ200 Parts List

Ref.	Part	Description	Qty.	Ref.	Part	Description	Qty.
1		TRAILER, GL7, hydraulic, 210 cfm	1	7	EQ1848	HOSE, water, EQ2040, 3/4 in. ID	1
		TRAILER, GL7, electric, 210 cfm	1	8	EQ1872	HOSE, air supply, air compressor	1
2		SYSTEM, blast, 200, trailer module	1	9		FITTING, bushing, 1 x 3/4 npt, sst	1
3	EQ1152	WASHER, flat, 1/2, sst	8	10		LABEL, VRM, Graco logo	2
4	EQ1519	BOLT, hex hd, 1/2 x 1-1/2, sst	4	11		FITTING, elbow, 90 degree	1
5	EQ1475	NUT, lock, nylon insert, 1/2, sst	4	13		FITTING, nipple, hex, 1 npt, sst	1
6	EQ5131	VALVE, water tank, shutoff, 3/4 in.	1	14		FITTING, elbow, 45 degree, ss, 1 in.	1

EQ4E03 Trailer

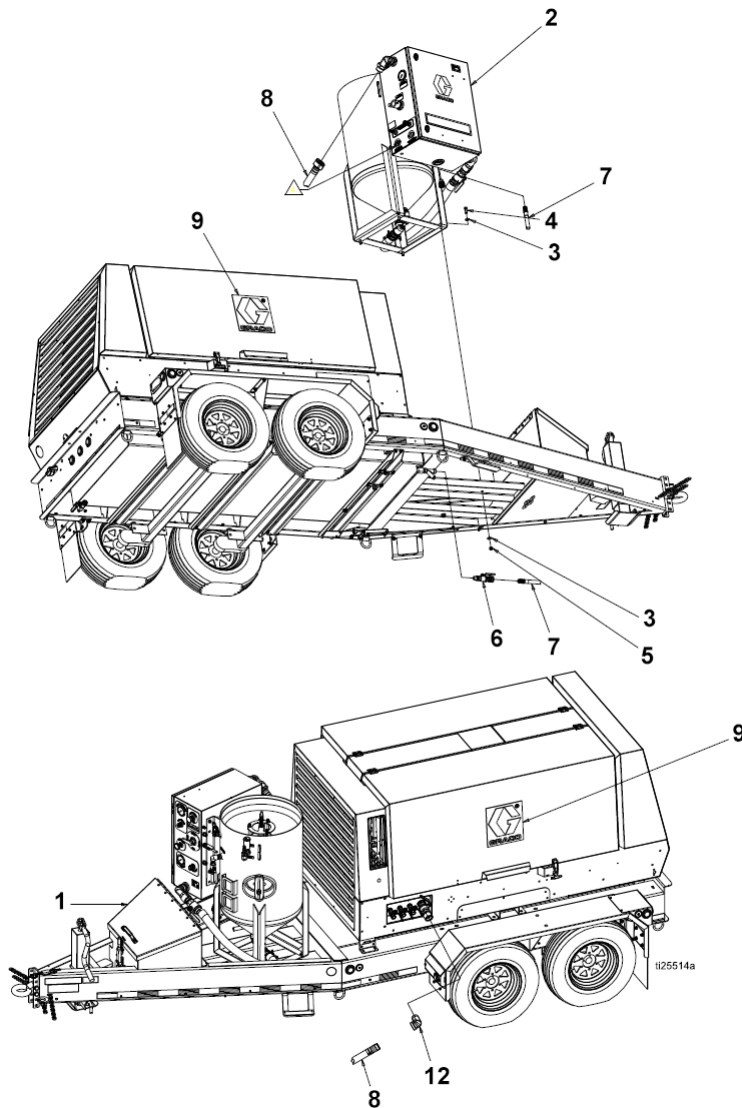

EQ4E03 Parts List

Ref.	Part	Description	Qty.	Ref.	Part	Description	Qty.
1		TRAILER, GL10, electric, 375 cfm	1	6	EQ5131	KIT, tank, shutoff valve	1
2		SYSTEM, blast, 400, trailer, module	1	7	EQ1848	HOSE, water, EQ2040, 3/4 in. ID	1
3	EQ1152	WASHER, flat, 1/2, sst	8	8	EQ1941	HOSE, air compressor to control	1
4	EQ1519	BOLT, hex hd, 1/2 x 1-1/2, sst	4	9		LABEL, VRM, Graco Logo	2
5	EQ1475	NUT, lock, nylon insert, 1/2, sst	4	12		FITTING, elbow, street, 1-1/2 npt, ss	1

Parts

EQ4E04 Trailer

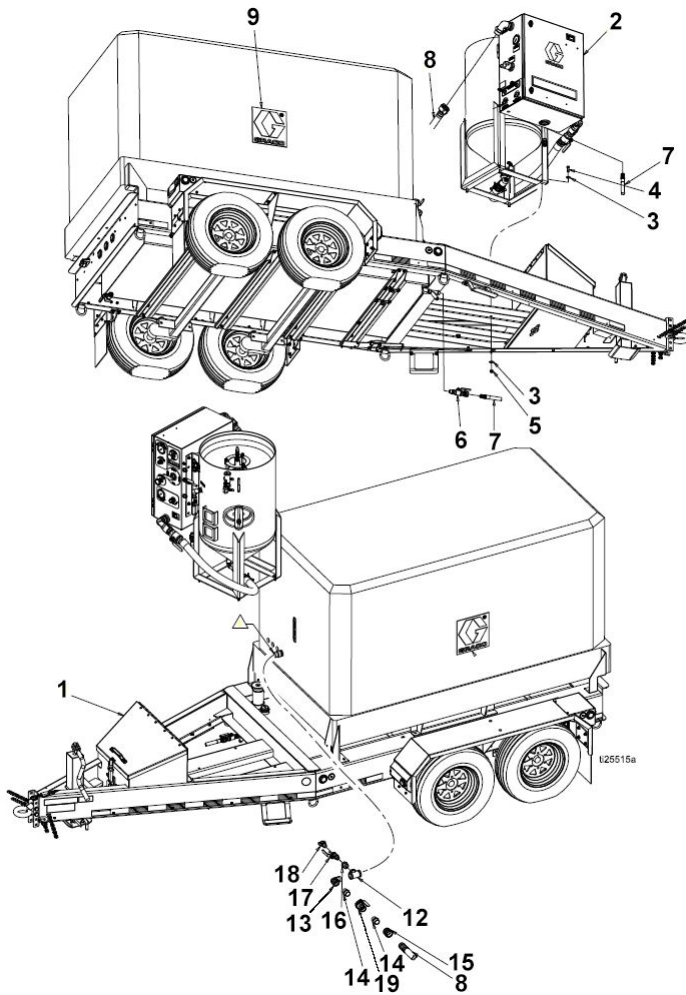

EQ4E04 Parts List

Ref.	Part	Description	Qty.	Ref.	Part	Description	Qty.
1		TRAILER, GL10, electric, 425 cfm	1	12		FITTING, tee, 1-1/4 npt, sst	1
2		SYSTEM, blast 400 trailer module	1	13		FITTING, elbow, street, 1-1/4 npt, sst	1
3	EQ1152	WASHER, flat, 1/2, sst	8	14		FITTING, nipple, hex, 1-1/4 npt, sst	2
4	EQ1519	BOLT, hex hd, 1/2 x 1-1/2, sst	4	15		FITTING, coupler, reducing, fpt, sst	1
5	EQ1475	NUT, lock, nylon insert, 1/2, sst	4	16		FITTING, reducer, 1-1/4 x 3/4 in.	1
6	EQ5131	KIT, tank, shutoff valve	1	17		VALVE, ball, vented, .750	1
7	EQ1848	HOSE, water, EQ2040, 3/4 in. ID	1	18		FITTING, hose, air, king, 3/4 in.	1
8	EQ1941	HOSE, air compressor to control	1	19		FITTING, ball, vented	1
9		LABEL, VRM, Graco logo	2				

Pressure Pot

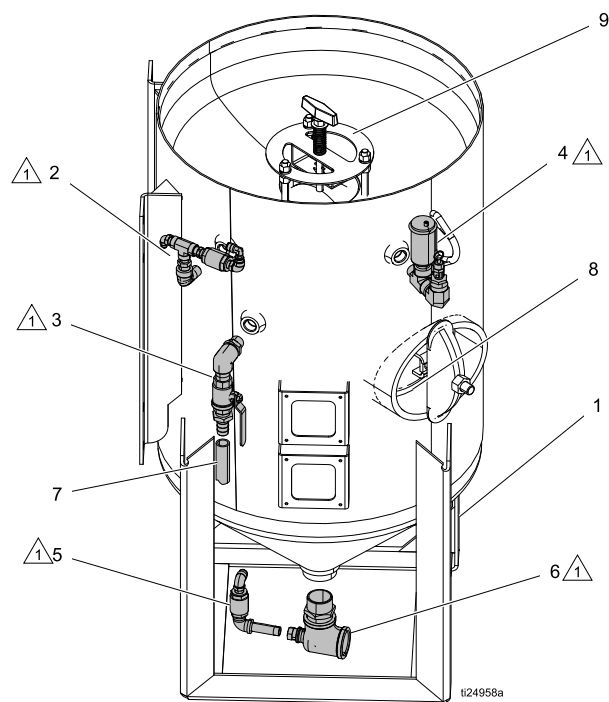

Pressure Pot Parts List

Ref.	Part	Description	Qty.	Ref.	Part	Description	Qty.
1		PRESSURE POT, blast, 6.5 cubic ft.	1	4		KIT, pressure pot, auto-vent	1
2		KIT, pressure pot, fill port	1	17D785		KIT, replacement, valve	
	102901	TEE, pipe		115813		FITTING, street elbow, 3/4 npt	
	123724	FITTING, nipple, hex, 1/2 in. npt x 3/8 in. npt		17D789		KIT, replacement, valve, auto-vent	
	166469	NIPPLE, pipe, hex		123514		FITTING, tee, run, 3/4 in., mff, ss, 3k	
	EQ1034	VALVE, check, in-line, ss 316		516308		FITTING, bushing, reducer, sst	
	EQ1500	FITTING, elbow, swivel, male, 3/8 in.		5	EQ5137	KIT, pressure pot, flush valve	1
	EQ1834	FITTING, connector, straight, male		6	EQ5148	KIT, pressure pot, unequal tee	1
	EQ1778	FITTING, elbow, street, 1/2 npt, sst		7	EQ1360	HOSE, clear, braided, 3/4 in. ID	3
3		KIT, pressure pot, dump valve	1	8	17D790	KIT, replacement, handway	1
	115813	FITTING, street elbow, 3/4 in. npt		9	17D741	KIT, replacement, pop-up	1
	190724	NIPPLE, sst					
	EQ1003	VALVE, ball, full port, npt, ss					
	EQ1012	FITTING, nipple, barb, hose, 3/4 in.					



Apply thread sealant to pipe threads.

Hose Schematic

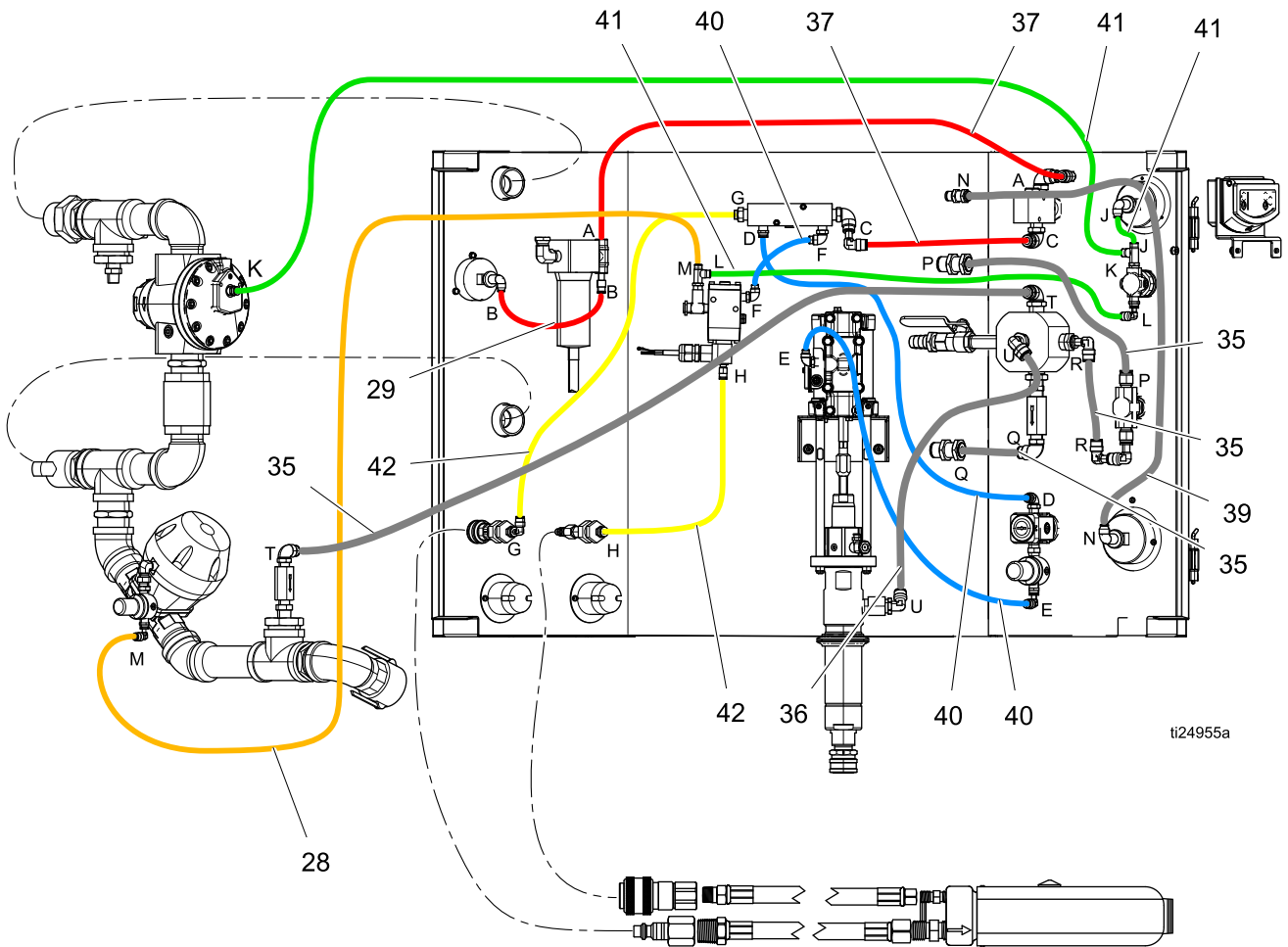

Ref.	Part	Cut Length	Ref.	Part	Cut Length
28	EQ1296	42.0 in.	40	EQ1883	32.0 in.
29	EQ1882	16.0 in.	40	EQ1883	20.75 in.
35	EQ1273	12.25 in.	41	EQ1884	7.38 in.
35	EQ1273	2.88 in.	41	EQ1884	10.5 in.
35	EQ1273	5.5 in.	41	EQ1884	11.25 in.
35	EQ1273	21.0 in.	41	EQ1884	19.88 in.
37	EQ1297	24.5 in.	42	EQ1885	34.5 in.
37	EQ1273	2.25 in.	42	EQ1885	17.0 in.
39	EQ1881	21.75 in.			

Vapor Abrasive Blast Systems and Accessories

EcoQuip Skid Systems

Model	Series		Package (blast hose and nozzle type)	Configuration
EQ	1	0	0	M
	1 = 100		0 = Bare Package (no blast hose or nozzle)	M = Mobile unit (100 series only)
	3 = 300		E = Complete package with 15 m (50 ft) blast hose, nozzle — Electric Blast Control	S = Skid Unit (not available on 100 series)
	6 = 600		P = Complete Package with 15 m (50 ft) blast hose, nozzle — Pneumatic Blast Control	C = No crash frame or water tank (not available on 100 series)

EcoQuip Trailer Systems

Model	Series	Brakes	Package (blast hose and nozzle type)	Compressor Configuration
EQ	2	H	0	3
	2 = 200 series	H = Hydraulic Brakes (<i>not available on 400 series</i>)	0 = Bare Package (<i>no blast hose or nozzle</i>)	3 = Tier 3 Compliant (<i>only available on 400 series</i>)
	4 = 400 series	E = Electric Brakes	E = Complete Package <i>with 50 ft (15 m) blast hose, nozzle — Electric blast control</i>	4 = Tier 4i Compliant
			P = Complete Package <i>with 50 ft (15 m) blast hose, nozzle — Pneumatic blast control</i>	

Mobile/Skid Units

Model	Series	Description
EQ100M	100 Series	Mobile unit, bare package
EQ10EM	100 Series	Mobile unit, complete package, electric blast control
EQ10PM	100 Series	Mobile unit, complete package, pneumatic blast control

Model	Series	Description
EQ300S	300 Series	Bare package
EQ300C	300 Series	No skid/crash frame or water tank, bare package
EQ30ES	300 Series	Complete package, electric blast control
EQ30EC	300 Series	No skid/crash frame or water tank, complete package, electric blast control
EQ30PS	300 Series	Complete package, pneumatic blast control
EQ30PC	300 Series	No skid/crash frame or water tank, complete package, pneumatic blast control

Model	Series	Description
EQ600S	600 Series	Bare package
EQ600C	600 Series	No skid/crash frame or water tank, bare package
EQ60ES	600 Series	Complete package, electric blast control
EQ60EC	600 Series	No skid/crash frame or water tank, complete package, electric blast control
EQ60PS	600 Series	Complete package, pneumatic blast control
EQ60PC	600 Series	No skid/crash frame or water tank, complete package, pneumatic blast control

*100/300 complete packages include 1 in. ID, 4 -ply hose (15 meter long) and #7 standard nozzle.
600 complete packages include 1.25 in. ID, 2-ply hose and #8 high performance nozzle.*

Trailer Units

Model	Description
EQ2H04	200 series, hydraulic brakes, bare package, Tier 4i
EQ2HE4	200 series, hydraulic brakes, complete package, electric blast control, Tier 4i
EQ2HP4	200 series, hydraulic brakes, complete package, Tier 4i
EQ2E04	200 series, electric brakes, bare package, Tier 4i
EQ2EE4	200 series, electric brakes, complete package, electric blast control, Tier 4i
EQ2EP4	200 series, electric brakes, complete package, pneumatic blast control, Tier 4i
EQ4E03	400 series, electric brakes, bare package, Tier 3
EQ4EE3	400 series, electric brakes, complete package electric blast control, Tier 3
EQ4EP3	400 series, electric brakes, complete package pneumatic blast control, Tier 3
EQ4E04	400 series, electric brakes, bare package, Tier 4i
EQ4EE4	400 series, electric brakes, electric blast control, Tier 4i
EQ4EP4	400 series, electric brakes, complete package, pneumatic blast control, Tier 4i

Hoses

Model	Description	Type	Length	Blast Control	ID	Model
EQ5237	Blast Hose	Extension	15 m (50 ft)	Pneumatic	1.0 in.	EQ100, EQ200, EQ300
EQ5235	Blast Hose	Extension	15 m (50 ft)	Electric	1.0 in.	
EQ5236	Blast Hose	Replacement	15 m (50 ft)	Pneumatic	1.0 in.	
EQ5234	Blast Hose	Replacement	15 m (50 ft)	Electric	1.0 in.	
EQ5077	Blast Hose	Extension	30 m (100 ft)	Pneumatic	1.25 in.	EQ400, EQ600
EQ5084	Blast Hose	Extension	30 m (100 ft)	Electric	1.25 in.	
EQ5082	Blast Hose	Extension	15 m (50 ft)	Electric	1.25 in.	
EQ5073	Blast Hose	Extension	15 m (50 ft)	Pneumatic	1.25 in.	
EQ5071	Blast Hose	Replacement	15 m (50 ft)	Pneumatic	1.25 in.	
EQ5080	Blast Hose	Replacement	15 m (50 ft)	Electric	1.25 in.	

Model	Description
17D786	Hose restraint
17D787	Coupler pin
17C459	Blast hose coupler gasket, hose end
17C124	Blast hose coupler gasket, machine end
17C125	Gasket, cam/groove, abrasive blast line – 1.25 in. ID (EQ300)
17C453	Gasket, cam/groove, abrasive blast line – 1.5 in. ID (EQ600)
EQ5183	Cable, battery
17D788	Replacement handle, pneumatic blast control
17D791	Replacement handle, electric blast control

Nozzles

Model	Description
EQ1710	Standard #7 (EQ100, EQ300, EQ200T)
EQ1711	Standard #8 (EQ600, EQ400T)
EQ7073*	High performance #7 (EQ100, EQ300, EQ200T)
EQ7074*	High performance #8 (EQ600, EQ400T)
EQ5166	Nozzle extension, 24 in.

**Performance nozzles require 100 psi (7 bar, 0.7 MPa) or more air pressure at nozzle.*

Common Spare Parts

Model	Description
17B186	KIT, repair, pump
17C124	KIT, gasket, hose coupler
17C125	KIT, gasket, quick coupler
17C127	KIT, repair, diaphragm valve (EQ300)
17C128	KIT, repair, diaphragm valve (EQ100, EQ600)
17C129	KIT, repair, regulator, air (EQ100)
17C131	KIT, repair, regulator, air (EQ600)
17C453	KIT, gasket, quick coupler
17C459	KIT, gasket, hose coupler
17D790	GASKET, handway 6 in. x 8 in. black ne
17D789	VALVE, auto-vent, 3/4 in.
17D785	KIT, replacement, pressure relief valve
17D786	KIT, replacement, hose restraint
17D787	KIT, replacement, coupler pin
206994	Throat Seal Liquid

Other Accessories

Model	Description
17C126	Pump Retrofit Kit
24A592	DataTrak Module and Reed Switch

Dimensions

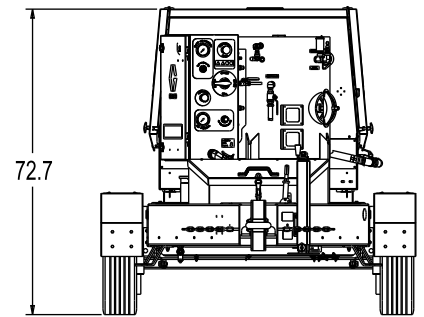
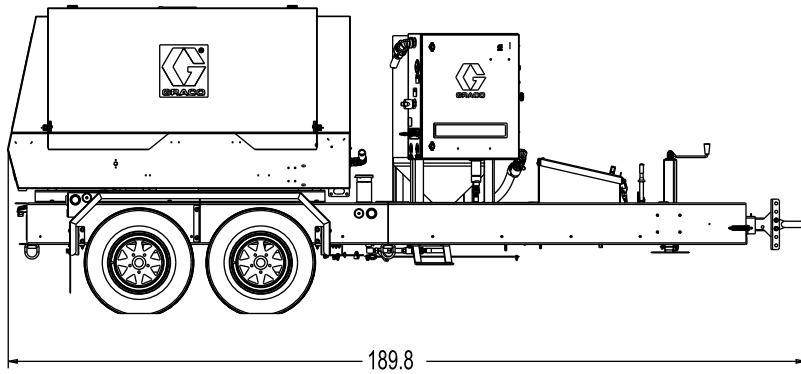
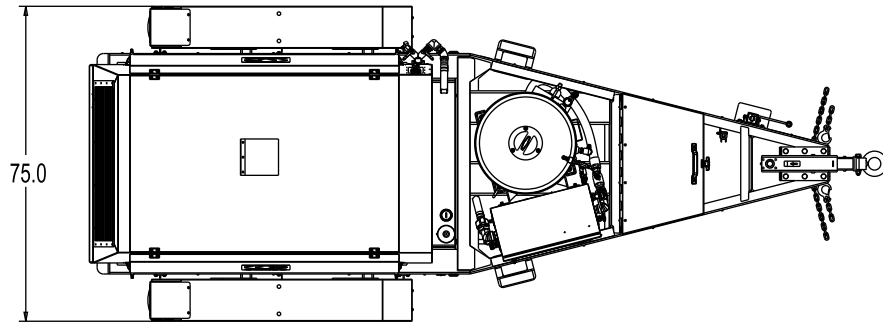

ti25445a

Technical Specifications

EQ200T	U.S.	Metric
Maximum Working Pressure	125 psi	8.6 bar, 0.86 MPa
Operating Temperature	35° – 110° F	1.6° – 43.3° C
Air Consumption	165 – 375 cfm	4.67–10.62 m ³ /min
Blast Hose Size	1 in. ID	25.4 mm ID
Abrasive Capacity	400 – 500 lb	181 – 227 kg
GVWR	6160 lb	2794 kg
Pressure Pot Volume	6.5 cubic feet	184 liters
Water Tank Volume	100 gallon	378 liters

Sound Data*

Sound Pressure Level	133 dB(A)	133 dB(A)
Sound Power Level	139 dB(A)	139 dB(A)
Instantaneous Sound Pressure Level	131 dB(C)	131 dB(C)

**All readings were taken at the maximum system blast pressure 125 psi (8.6 bar, 0.86 MPa) from the operator position. The abrasive used was garnet and the substrate was steel. Tested in accordance with ISO 9614-2.*

EQ400T	U.S.	Metric
Maximum Working Pressure	125 psi	8.6 bar, 0.86 MPa
Operating Temperature	35° – 110° F	1.6° – 43.3° C
Air Consumption	375 – 600 cfm	10.62–17.0 m ³ /min
Blast Hose Size	1.25 in. ID	31.75 mm ID
Abrasive Capacity	400 – 500 lb	181 – 227 kg
GVWR	11000 lb	4990 kg
Pressure Pot Volume	6.5 cubic feet	184 liters
Water Tank Volume	130 gallon	492 liters

Sound Data*

Sound Pressure Level	133 dB(A)	133 dB(A)
Sound Power Level	139 dB(A)	139 dB(A)
Instantaneous Sound Pressure Level	131 dB(C)	131 dB(C)

**All readings were taken at the maximum system blast pressure 125 psi (8.6 bar, 0.86 MPa) from the operator position. The abrasive used was garnet and the substrate was steel. Tested in accordance with ISO 9614-2.*

Notes

Graco Extended Warranty for EcoQuip™ Components

Graco warrants all equipment referenced in this document which is manufactured by Graco and bearing the Graco or EcoQuip name to be free from defects in material and workmanship on the date of sale to the original purchaser for use. Graco will, for three (3) years from the date of sale, repair or replace any part of the equipment determined by Graco to be defective. This warranty applies only when the equipment is installed, operated and maintained in accordance with Graco's written recommendations.

This warranty does not cover, and Graco shall not be liable for general wear and tear, or any malfunction, damage or wear caused by faulty installation, misapplication, abrasion, corrosion, inadequate or improper maintenance, negligence, accident, tampering, or substitution of non-Graco component parts. Nor shall Graco be liable for malfunction, damage or wear caused by the incompatibility of Graco equipment with structures, accessories, equipment or materials not supplied by Graco, or the improper design, manufacture, installation, operation or maintenance of structures, accessories, equipment or materials not supplied by Graco.

This warranty is conditioned upon the prepaid return of the equipment claimed to be defective to an authorized Graco distributor for verification of the claimed defect. If the claimed defect is verified, Graco will repair or replace free of charge any defective parts. The equipment will be returned to the original purchaser transportation prepaid. If inspection of the equipment does not disclose any defect in material or workmanship, repairs will be made at a reasonable charge, which charges may include the costs of parts, labor, and transportation.

THIS WARRANTY IS EXCLUSIVE, AND IS IN LIEU OF ANY OTHER WARRANTIES, EXPRESS OR IMPLIED, INCLUDING BUT NOT LIMITED TO WARRANTY OF MERCHANTABILITY OR WARRANTY OF FITNESS FOR A PARTICULAR PURPOSE.

Graco's sole obligation and buyer's sole remedy for any breach of warranty shall be as set forth above. The buyer agrees that no other remedy (including, but not limited to, incidental or consequential damages for lost profits, lost sales, injury to person or property, or any other incidental or consequential loss) shall be available. Any action for breach of warranty hereunder must be brought within the latter of two (2) years of the date of sale, or one (1) year after the warranty period expires.

GRACO MAKES NO WARRANTY, AND DISCLAIMS ALL IMPLIED WARRANTIES OF MERCHANTABILITY AND FITNESS FOR A PARTICULAR PURPOSE, IN CONNECTION WITH ACCESSORIES, EQUIPMENT, MATERIALS OR COMPONENTS SOLD BUT NOT MANUFACTURED BY GRACO. These items sold, but not manufactured by Graco (such as electric motors, switches, compressors, engines, trailer components, blast hose or other hose and blast nozzles), are subject to the warranty, if any, of their manufacturer. Graco will provide purchaser with reasonable assistance in making any claim for breach of these warranties.

In no event will Graco be liable for indirect, incidental, special or consequential damages resulting from Graco supplying equipment hereunder, or the furnishing, performance, or use of any products or other goods sold hereto, whether due to a breach of contract, breach of warranty, the negligence of Graco, or otherwise.

FOR GRACO CANADA CUSTOMERS

The Parties acknowledge that they have required that the present document, as well as all documents, notices and legal proceedings entered into, given or instituted pursuant hereto or relating directly or indirectly hereto, be drawn up in English. Les parties reconnaissent avoir convenu que la rédaction du présente document sera en Anglais, ainsi que tous documents, avis et procédures judiciaires exécutés, donnés ou intentés, à la suite de ou en rapport, directement ou indirectement, avec les procédures concernées.

Graco Information

For the latest information about Graco products, visit www.graco.com.

For patent information, see www.graco.com/patents.

To place an order, contact your Graco Distributor or call to identify the nearest distributor.

Phone: 612-623-6921 **or Toll Free:** 1-800-328-0211 **Fax:** 612-378-3505

All written and visual data contained in this document reflects the latest product information available at the time of publication.

Graco reserves the right to make changes at any time without notice.

Original Instructions. This manual contains English. MM 334666

Graco Headquarters: Minneapolis

International Offices: Belgium, China, Japan, Korea

GRACO INC. AND SUBSIDIARIES • P.O. BOX 1441 • MINNEAPOLIS MN 55440-1441 • USA

Copyright 2014, Graco Inc. All Graco manufacturing locations are registered to ISO 9001.

www.graco.com

Revision B, December 2014